

TAPPED HOLES: 6 TOTAL
(2 OPTIONAL LOCATIONS)

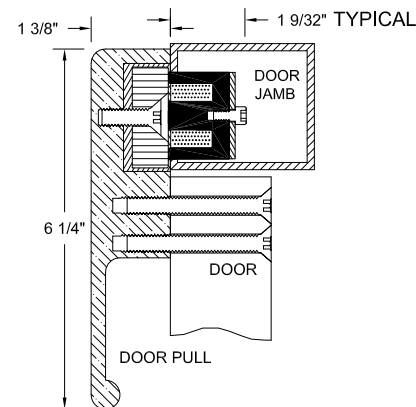
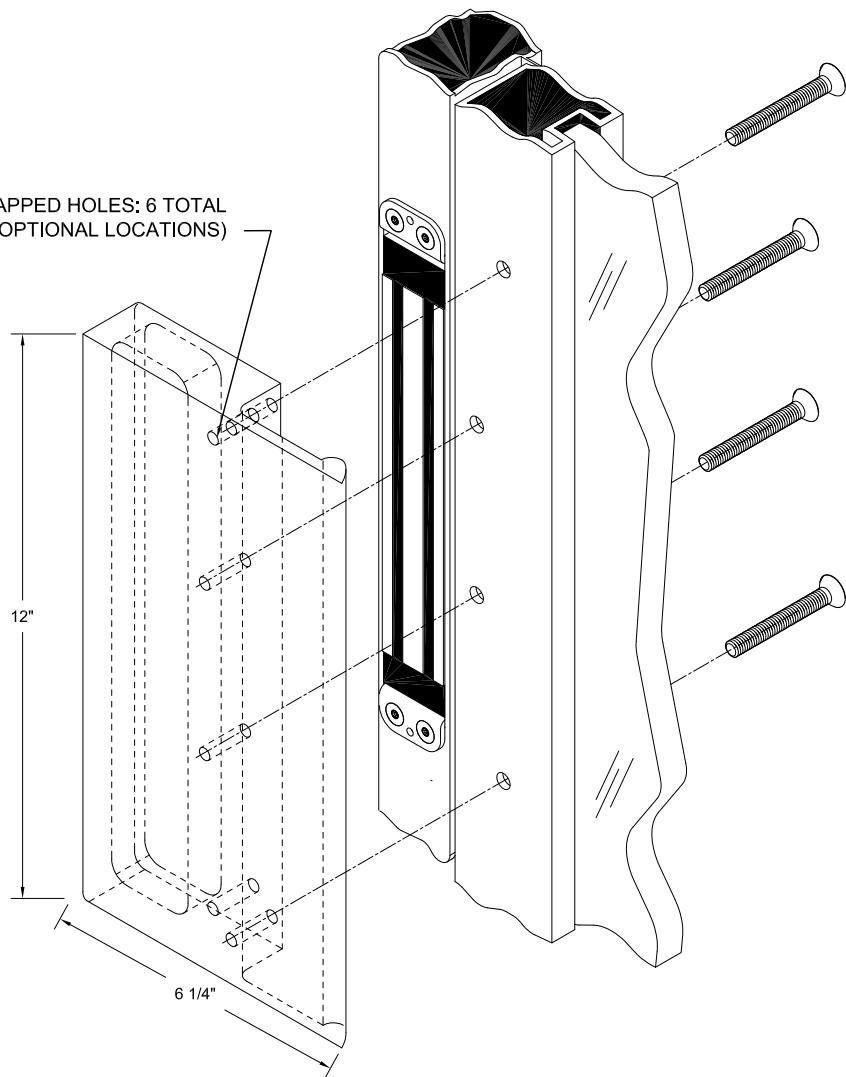

INSTALLATION

1. USE TEMPLATE SUPPLIED TO MARK DOOR & JAMB

ML-1100 = 10" X 1 $\frac{17}{32}$ "

ML-1106 = 6 $\frac{1}{16}$ " X 1 $\frac{17}{32}$ "

2. CUT OUT JAMB TO RECEIVE MAGNET. **MAKE OPENING NO LARGER THAN REQUIRED.** FOR DPS OPTION, SEE ACCOMPANYING LITERATURE

3. USE MAGNET ASSEMBLY TO MARK SCREW HOLES IN FRAME TOP & BOTTOM:
(4) # 12 SCREWS (2) # 6 SCREWS.

4. DRILL AND COUNTER SINK THE (2) # 6 SCREW HOLES ($\frac{5}{32}$ DRILL BIT) FOR MOUNTING THE (2) MOUNTING BLOCKS (TOP AND BOTTOM). THE COUNTERSINK SHOULD ALLOW THE SCREW HEADS TO SIT SLIGHTLY BELOW FLUSH WHEN TIGHT. **DO NOT OVERSIZE.**

5. DRILL THE (4) # 12 MOUNTING SCREW CLEARANCE HOLES ($\frac{1}{4}$ DRILL BIT).

6. MAKE SURE FIELD WIRING IS RUN IN JAMB AND IS READY TO BE CONNECTED.

7. INSTALL TOP AND BOTTOM MOUNTING BLOCKS - DO NOT TIGHTEN SCREWS UNTIL ASSEMBLY IS COMPLETE.

8. TAKE CARE THAT THE BLOCKS DO NOT FALL INTO THE JAMB. USE TAPE OR CLAMP TO SECURE THE BLOCKS WHILE SCREWS ARE INSTALLED OR TIE A LENGTH OF LINE THROUGH THE LARGER HOLES TO MAKE RETRIEVAL EASIER.

9. COMPLETE WIRING CONNECTIONS AND INSTALL MAGNET ASSEMBLY - INSERT, BUT DO NOT FULLY TIGHTEN THE 4 MOUNTING SCREWS.

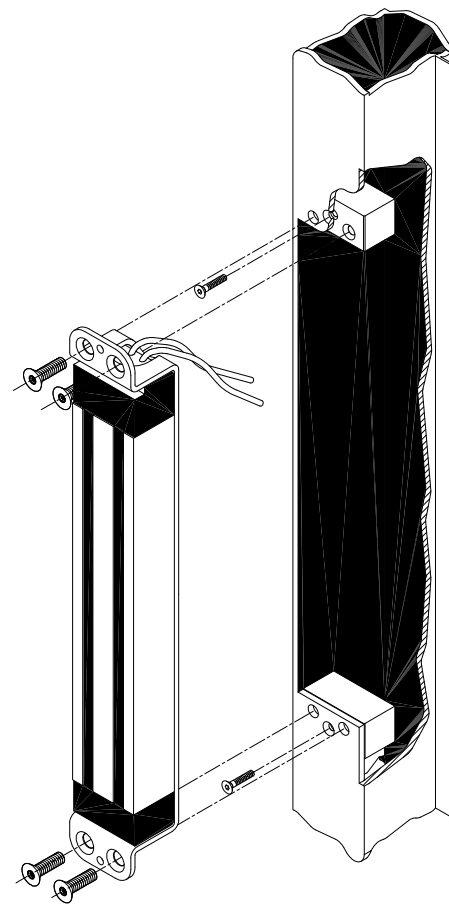

REV -A 1-23-09 WAS 10-1/16" JTF

FINISH: -

PAGE 1 OF 3

DWG # 1110 DP ASSEMBLY

MATERIAL: -

DATE:
06/18/08

BY:
JFH

INSTALLATION NOTES

NOT TO SCALE



DORTRONICS
SYSTEMS, INC.
SAG HARBOR, NY
800-906-0137

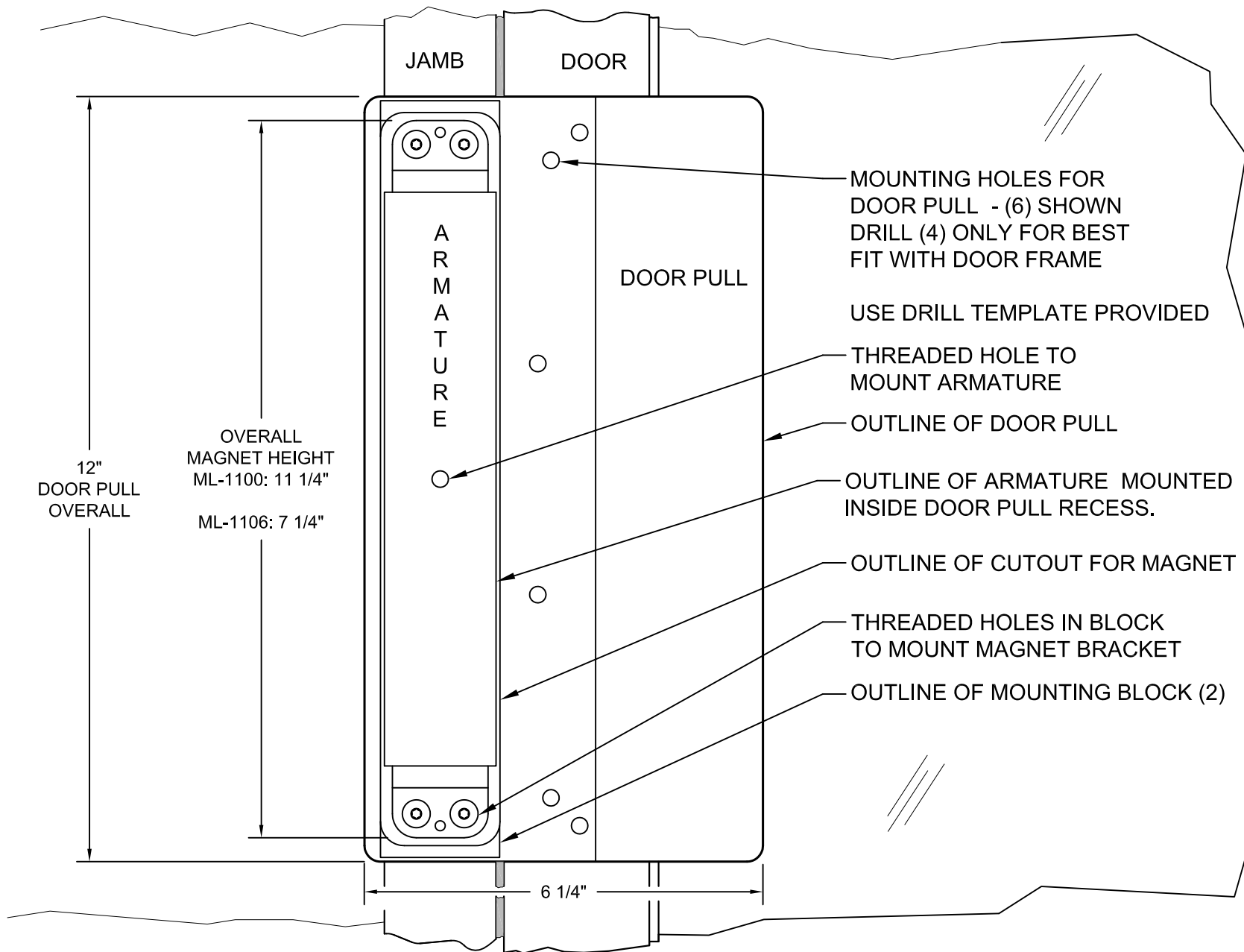

REV -	FINISH: -	PAGE 1 OF 1		DWG# ML-1100 SERIES	 DORTRONICS SYSTEMS, INC. SAG HARBOR, NY 800-906-0137
	MATERIAL: -	DATE: 06/18/08	BY: JFH	MOUNTING DIAGRAM	
	TOL. XXX +/- .010			MORTISED JAMB LOCK	

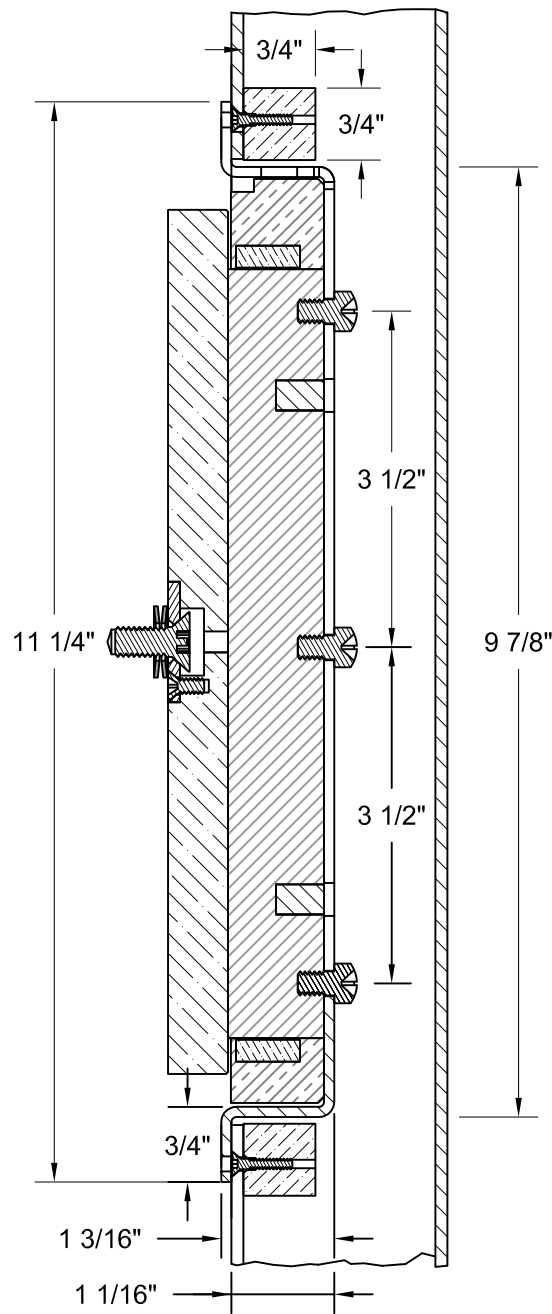

- DOOR HANDLE
- SPRING WASHERS (2)
- ARMATURE MOUNTING SCREW
- ARMATURE
- MAGNET ENCLOSURE
- MAGNET
- MOUNTING BRACKET
- MOUNTING BLOCK WITH MOUNTING SCREW

NOTE: ARMATURE MUST BE FREE TO ALIGN ITSELF WITH FACE OF MAGNET TO INSURE FULL HOLDING FORCE. USE SPRING WASHERS PROVIDED.

REV A	FINISH: GRAIN, CLEAR ANODIZED	PAGE 1 OF 1		DWG# 1110-DP	DORTRONICS SYSTEMS, INC. SAG HARBOR, NY 800-906-0137
	MATERIAL: 6061-T6 ALUM.	DATE: 06/20/08	BY: JFH	SECTION DRAWING	
	TOL. XXX +/- .010				