



INTERLOCK SOLUTIONS

DESIGN GUIDE FOR INTERLOCKING DOOR SYSTEMS



POWER



LOCKS

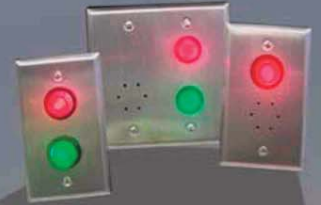

INDICATORS



EXIT ALARMS

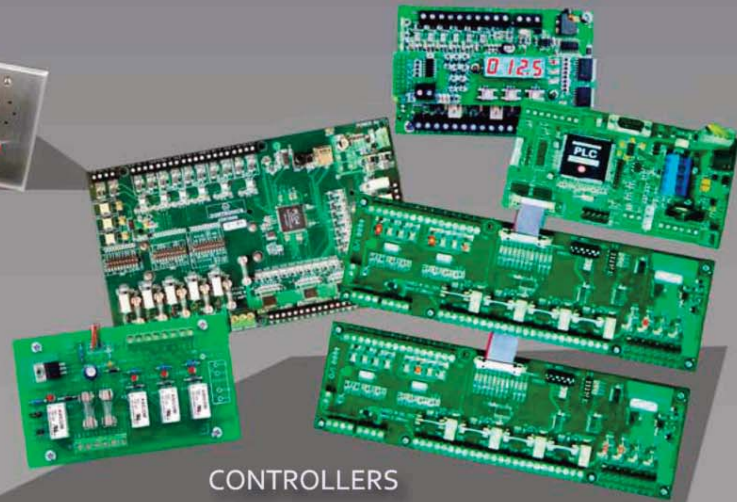

CONTROLLERS



ACTUATORS



CUSTOM PANELS



Dortronics Systems, Inc., is a U.S. manufacturer of electric locking hardware, it is the security industry's "quick-ship" supplier of standard and customized access control devices. Standard products include: electromagnetic locks; electric strikes; door interlock systems; power supplies; key switch controls; pushbutton switches; digital keypads; stand-alone door props; delayed egress systems; alarm annunciators; security consoles; high security locks; PIR motion sensing door releases; and emergency pull stations.

Electromagnetic locks, egress bars and switch controls are stocked in most architectural finishes to complement other building hardware finishes.

With in-house engineering and manufacturing, Dortronics can customize existing products or create a totally new solution for your access control problem.

Competitively priced, most orders ship within a day. With representation throughout the United States and Internationally Dortronics provides unmatched quality service and technical support.

Off the shelf, or off the drawing board Dortronics delivers.

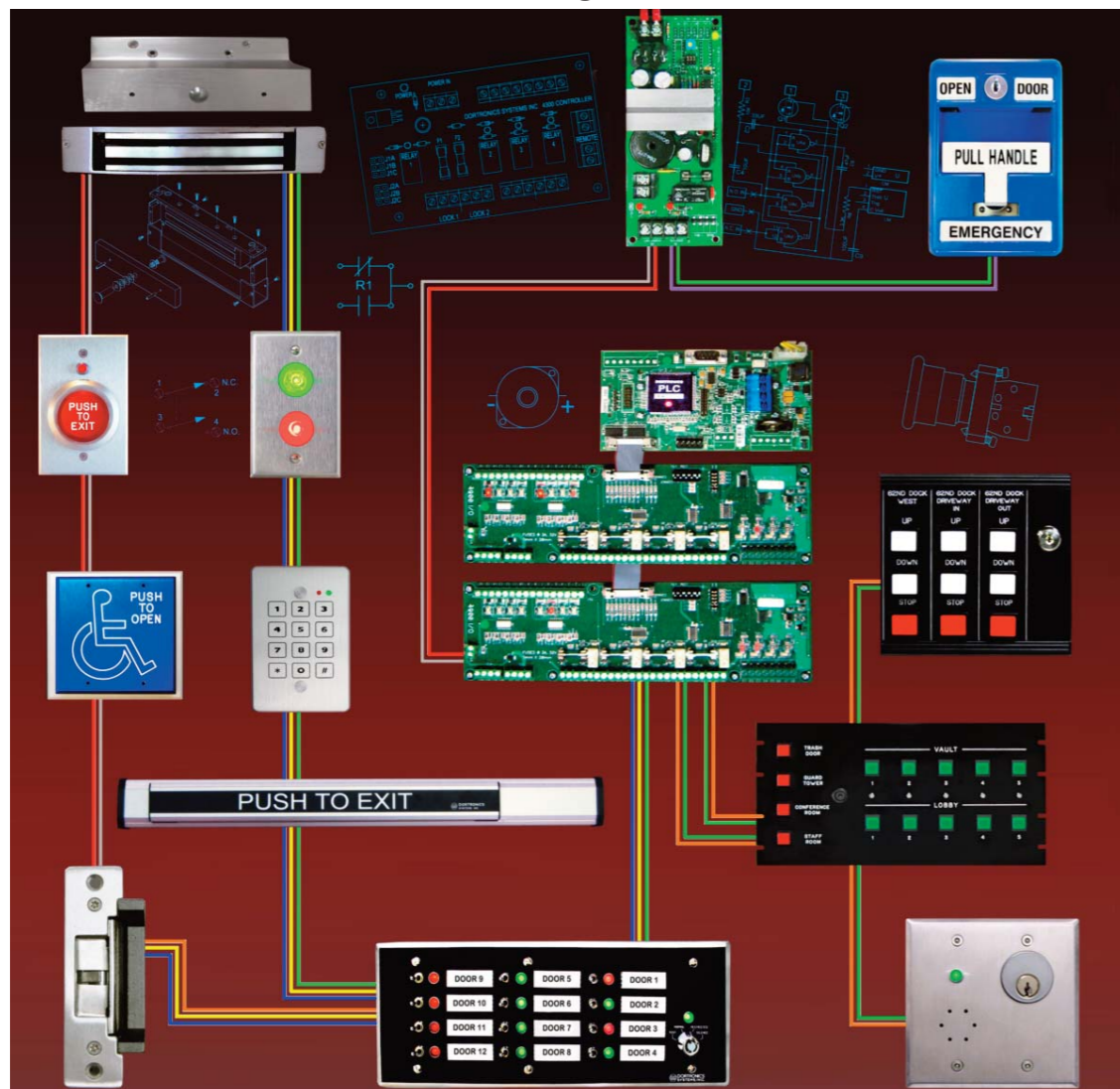

4000 SERIES INTERLOCKS & MANTRAP CONTROL

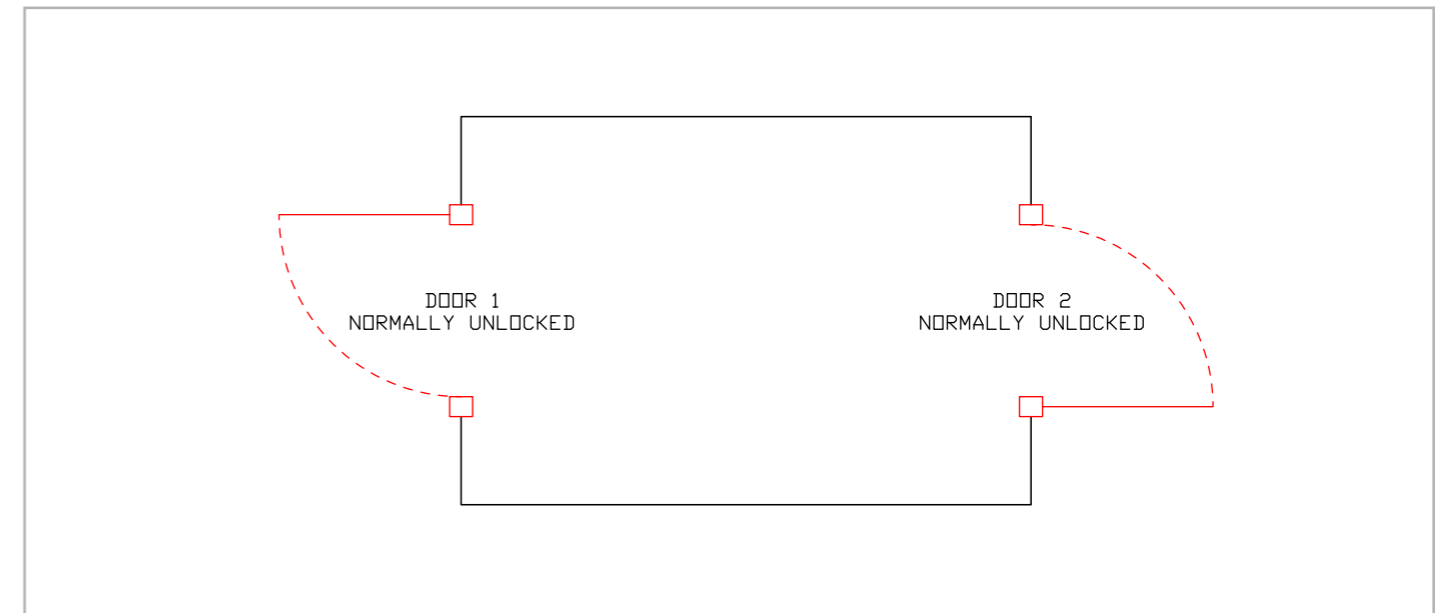

Considerations -

Mantraps are often manual swing doors forming a vestibule but they can also utilize automatic doors or gates. Two door mantraps are most common but systems can incorporate thirty or more doors when several controlled areas are interconnected.

Clean rooms require clean air separation for a controlled environment. These air locks may also utilize air pressurization to maintain the sterile area. Some "air locks" use normally unlocked doors, however better systems will utilize doors that are normally locked with push button release stations on each. This insures that two or more doors cannot be opened simultaneously.

Security interlocks typically incorporate doors that are normally locked. Traffic flow can be improved for less secure areas by allowing the interior doors to be unlocked while the perimeter doors are locked. If automatic door operators are installed, electric locks may not be required if the activation signal from the push button or motion detector can be interrupted by the interlock control to inhibit the door from opening. Automatic sliding doors and swing doors with electromechanical locks require special locking systems integrated with the automatic door operator.

Life safety codes may be involved when mantraps are used to limit ingress and egress. These will require that door interlock system be interfaced to the fire alarm control to allow an emergency door release. A local emergency pull station may be required to allow doors to be unlocked in non-fire alarm emergencies or to interface the mantrap system with NFPA 101 delayed egress controls. The most reliable systems provide for an independent door interlock controller to be separate from the computerized card access system for ease of service.

The local building code agency should always be consulted before installation of the locking system. There are situations where no locks restricting an exit are permitted. In these systems only traffic lights are used to indicate when entry or exit is permitted.

Types of Operations

Normally Unlocked (Air Lock Control) – These are most often low-security systems used only for environmental control. All doors are normally unlocked. Opening any door will lock all other related doors. This provides easy ingress or egress with no waiting before access if other doors are closed. This type is the least secure as two or more doors may be opened simultaneously. Typically this design incorporates door position switches to control the mantrap system.

Secure Entry / Free Egress – This system provides a more secured entrance system will allowing a faster method of egress through a combination of locked and unlocked doors. Exterior doors are normally secured and interior doors normally unlocked. A card access system controls entry from the exterior and an R-E-X device is used on the interior of the outside door. A valid access card will unlock the exterior door only if the interior door is closed. Unlocking the exterior door will lock the interior door. Once the exterior door is re-secured, the interior door is unlocked to allow access into the facility. Opening the interior door prevents the exterior door from being unlocked

Restricted Entry & Exit – Highest security is provided when all doors are normally locked. A door is unlocked by a request for access if no other doors are unsecured. Opening any door keeps all other doors secure. The more secure mantrap systems will buffer simultaneous requests for access to prevent two or more doors from being unlocked. The best designs utilize lock monitoring sensors in lieu of door switches.

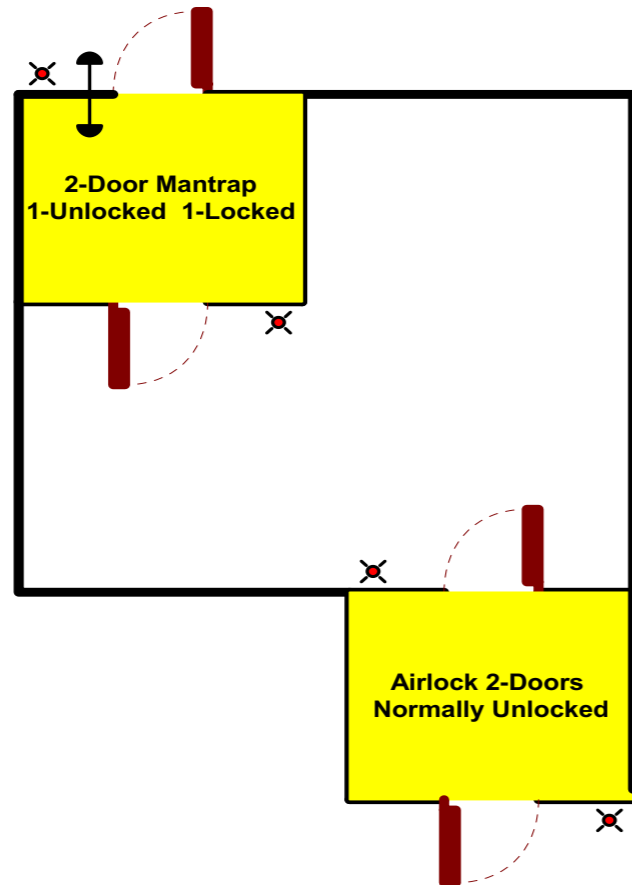

Interlocking Door Relationships

While the number of doors and controlled devices will determine the PLC interlock series, the desired operation must be described also. The door relationships can be specified by text and/or a door matrix chart.

Typical configuration chart for a 4-Door / 3-Room with 2-Shared Doors Normally Unlocked / 2-Unshared Doors Normally Locked –

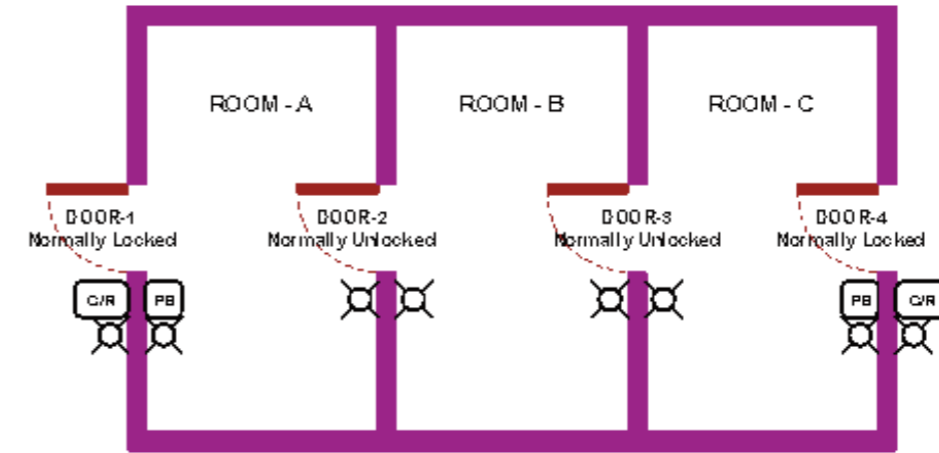

Door #	Type	Room-A	Room-B	Room-C
1	Locked	X		
2	Unlocked	X	X	
3	Unlocked		X	X
4	Locked			X

OPERATION:

- 1) If Door-1 is open, secure Door-2
- 2) If Door-2 is open, secure Door-1 and Door-2
- 3) If Door-3 is open, secure Door-2 and Door-4
- 4) If Door-4 is open, secure Door-3

Doors 'shared' between rooms generally inhibit all other doors in both rooms. Since these doors are already within the secure area, they can sometimes be specified as normally unlocked to increase traffic flow.

Some projects will require traffic to flow only in one direction to limit contamination. By using request-for-access devices on only one side of the door, traffic can be directed as needed.

Automatic doors and vehicle gates should be controlled as normally locked doors by using the lock relay output to disable the "open" trigger device (push button, motion sensor, vehicle detector, etc.) Most door and gate operators have a built-in "close" operation whenever the "open" signal is inactive. Other gate controls may require a separate "close" signal which will require an additional output relay. Specify dedicated contacts to signal the interlock controller of door/gate status. Verify the control logic of these systems to insure that safety and compatibility is maintained. It is best to leave the "stop" control station uninhibited to allow immediate override in an emergency.

4300 Series Relay Interlocks

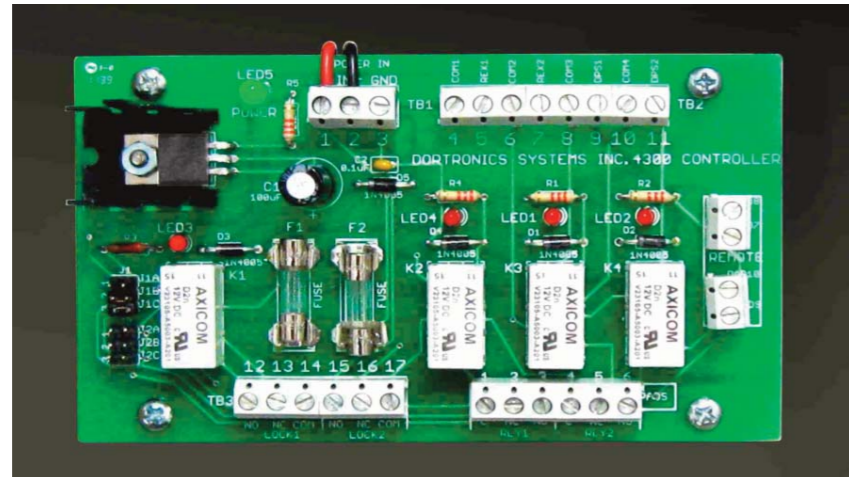

The 4300 series are economical relay logic controls for two door mantraps not requiring any timing cycles or special operating features. These controllers accept two door status inputs and two request-for-access inputs plus provide two DPDT relay outputs. One set of relay contacts is used for lock control and one set for indicator lights or remote monitoring. The lock relay follows the REX input status when access is permitted. If a card access system or push buttons with timers are not used, specify the AT-timer option for a delayed re-lock function. The remote panic override feature may be used for one or both doors

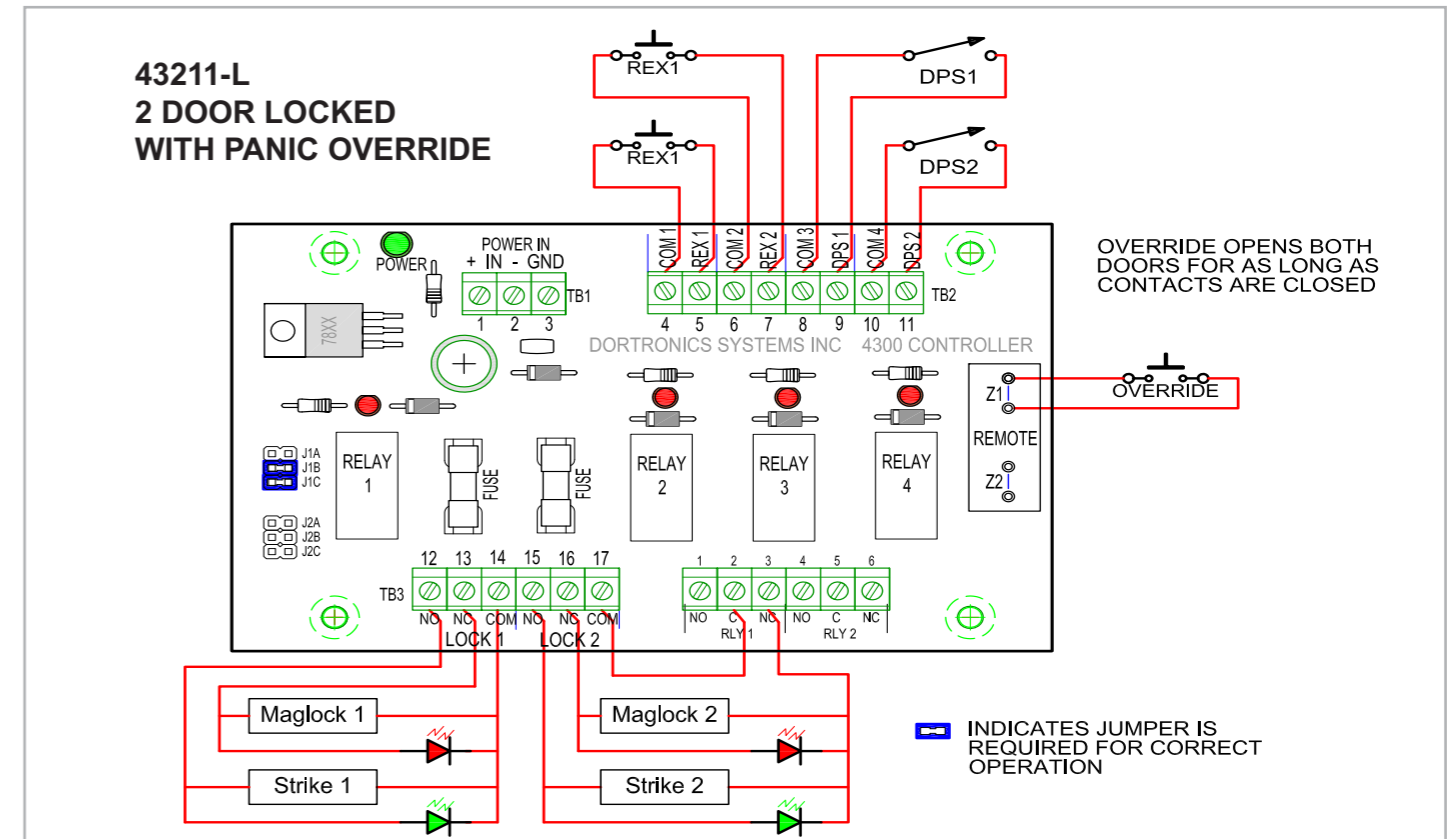

4700 Series PLC Interlocks

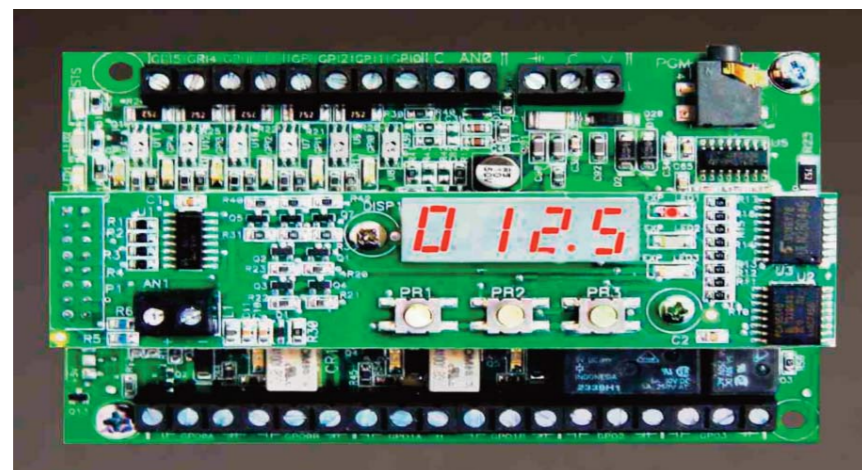

These economical PLC interlocks are factory programmed for systems with two or three normally locked doors or up to four normally unlocked door systems. Eight standard configurations are offered, plus customized operations. With six inputs, two DPDT relays and two SPDT relays, this controller can be used for multi-room systems with shared doors between rooms and/or activate other devices. This controller can also control traffic lights to provide indication to users when the doors are available for access. The optional LED display can be used facilitate adjustment of time delay.

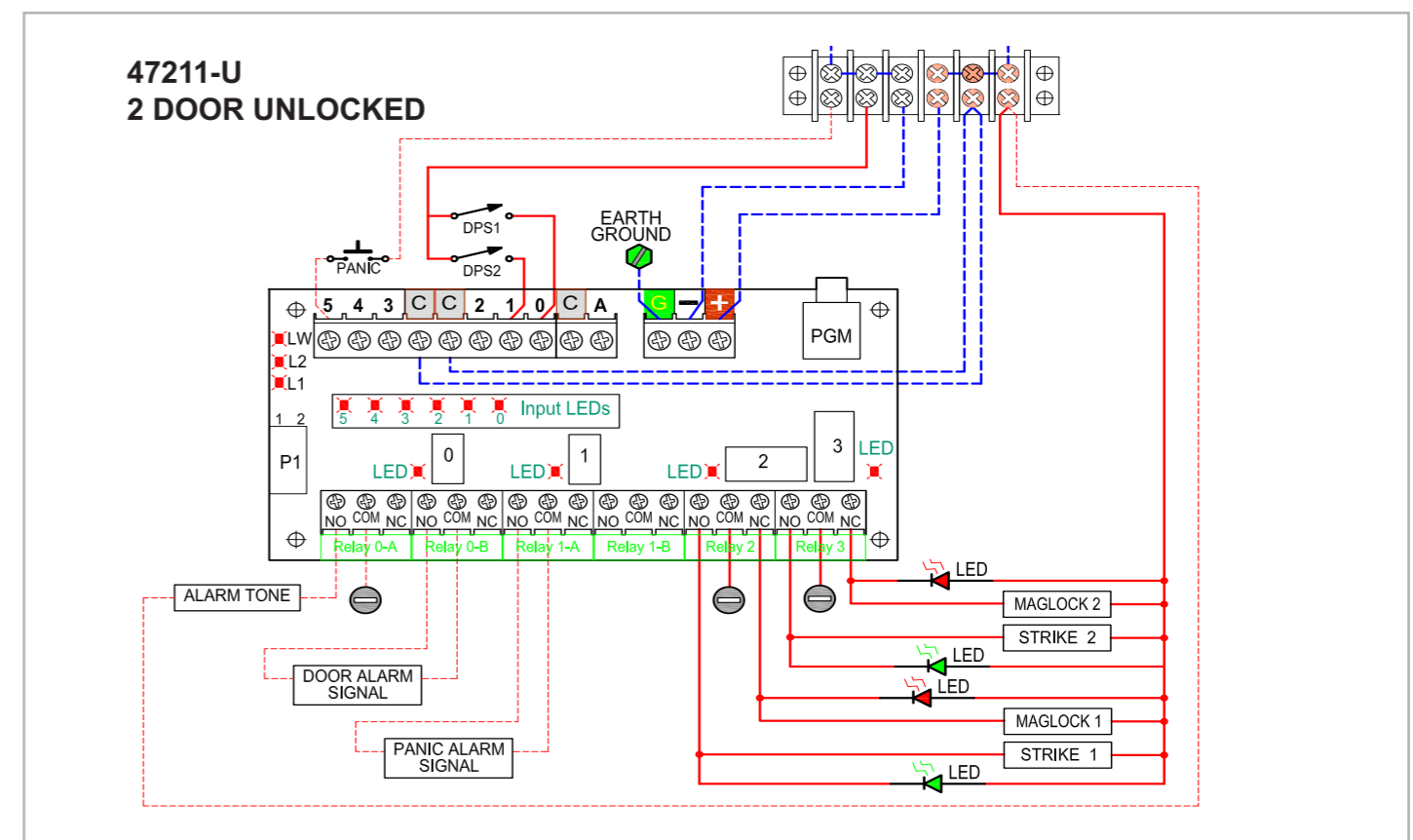

4800 SERIES USER CONFIGURED INTERLOCKS

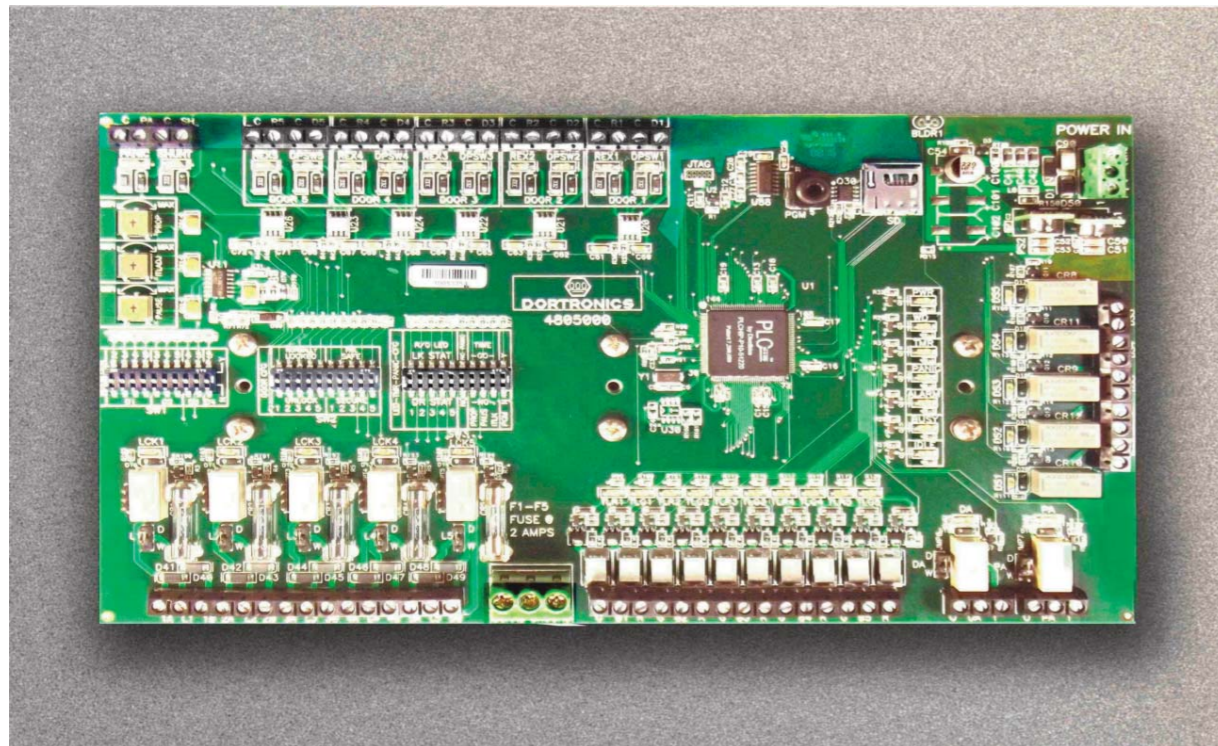

FIVE DOOR LOCKED EXAMPLE

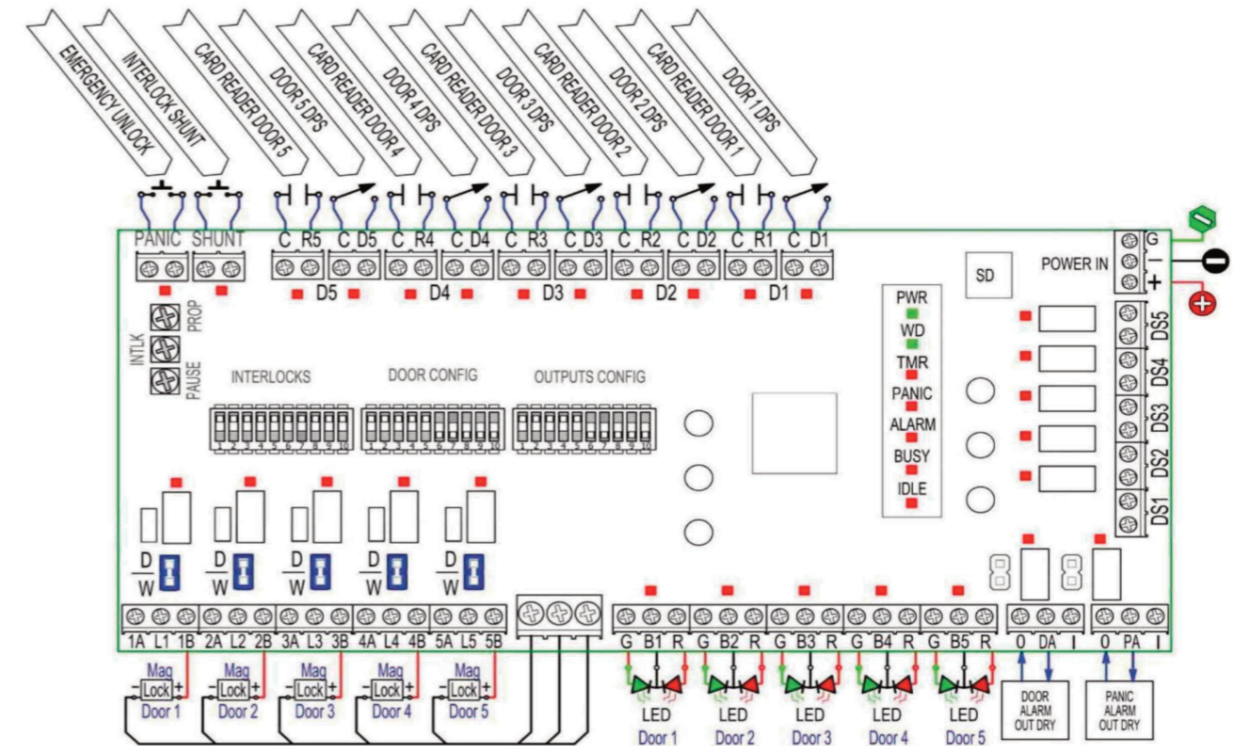

Field Selectable Door Sequence & Functions

The 4800 PLC interlock controller is a cost effective method for operating door interlock and mantrap systems of up to five doors. The fully integrated controller is a one board solution that allows the installer complete control of all operating and configuration options without complex software.

Environmental or Security Applications

Suitable for air locks or security mantraps, with up to five normally locked or unlocked doors. This controller may be customized to control automatic door openers and provide custom timing and logic sequences for biological wash-down controls. Other configurations provide outputs for traffic lights, forced door alarms and an emergency panic release input.

Access Control Compatible

Any access control system can be used with the 4800 series controllers. The request for access input recognizes any normally open dry contact. Each door has a normally open dry contact output to mirror door status back to an access control panel or remote console

Available with 12/24 VDC Power Supply

The 48501 series PLC controller is paired with a heavy duty 4-amp power supply that includes a Fire Alarm connection for emergency egress and can provide power to operate maglocks, electric strikes and traffic lights. The controller is also available without the power supply & enclosure for connection to an existing 12-24VDC power source.

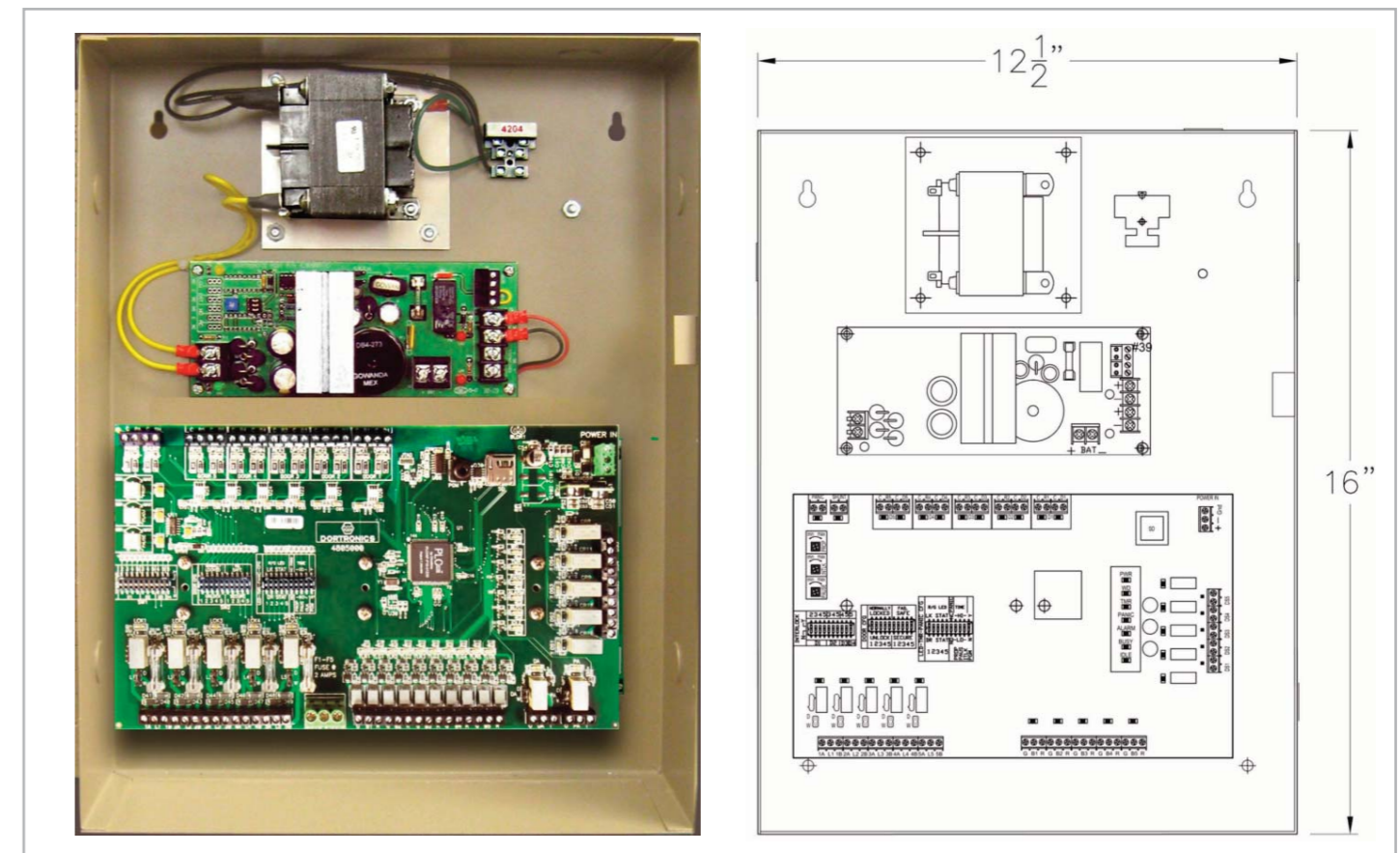

4900 SERIES PLC MULTI DOOR INTERLOCKS

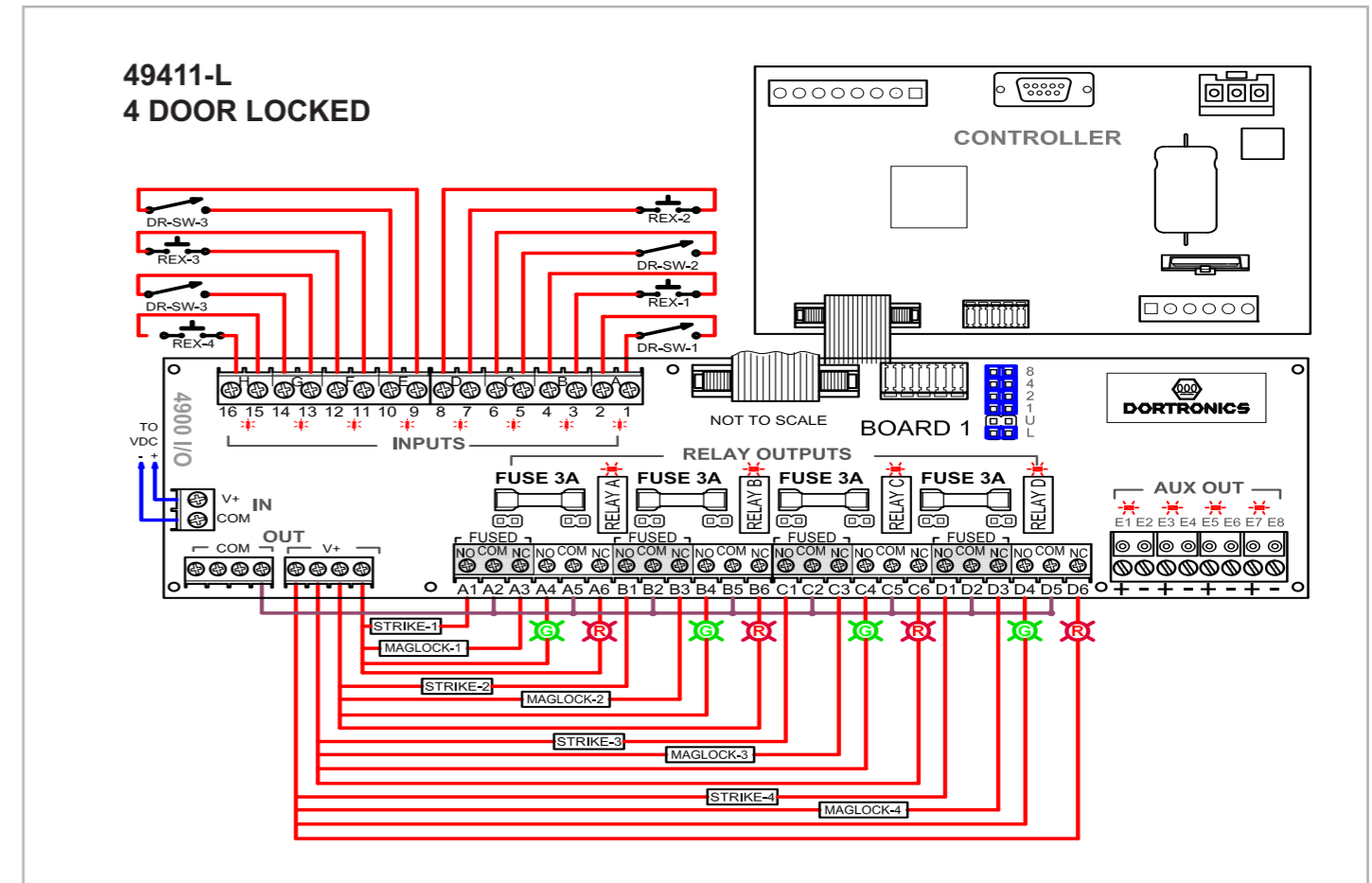
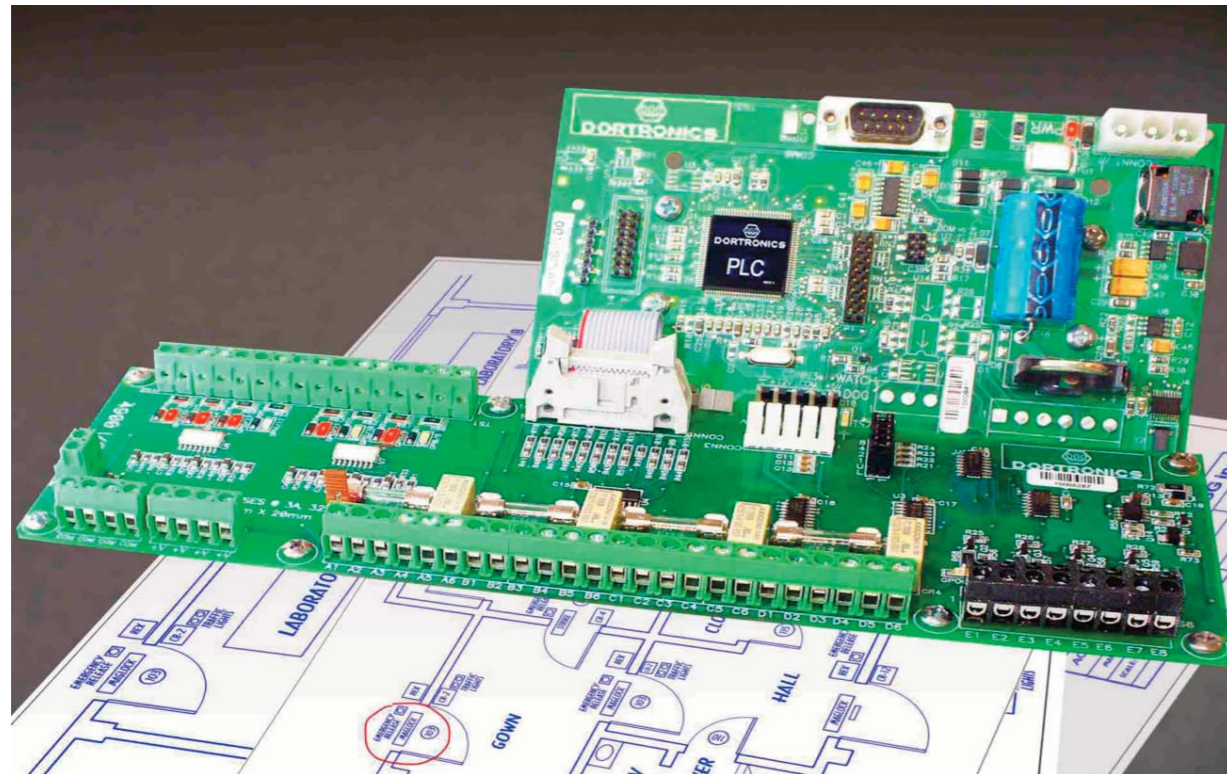

These PLC based interlocks can be configured for systems in excess of 100 doors. All PLC controllers are factory programmed and tested before shipment. Standard interlock configurations are offered for two, three and four door systems. Customized programming is available for these smaller systems with special requirements. Large and complex interlocks are configured using multiple input/output modules and add-on relay expansion boards for cost effective expansion. The optional LED display module allows specialized functions to be user adjustable without reprogramming.

All mantrap controls are installed to monitor interlocked door status and directly control the electric locking device on these doors. The normal lock control relay of the card access system or local push button is used to provide the access request input for normally locked doors.

Dortronics interlock controls are supplied with a 12/24 VDC 4 amp power supply and fire alarm interface relay with NEMA enclosure. PLC controllers are available with additional power supplies for large multi-door systems.

All interlock systems require dedicated, dry contacts for door status and request for access inputs. If contacts are also needed for use by other controls, inputs can be mirrored by relay outputs on PLC systems when required.

Optional LED display modules are available to allow field adjusts of timing delays or to allow the user to select special operations.

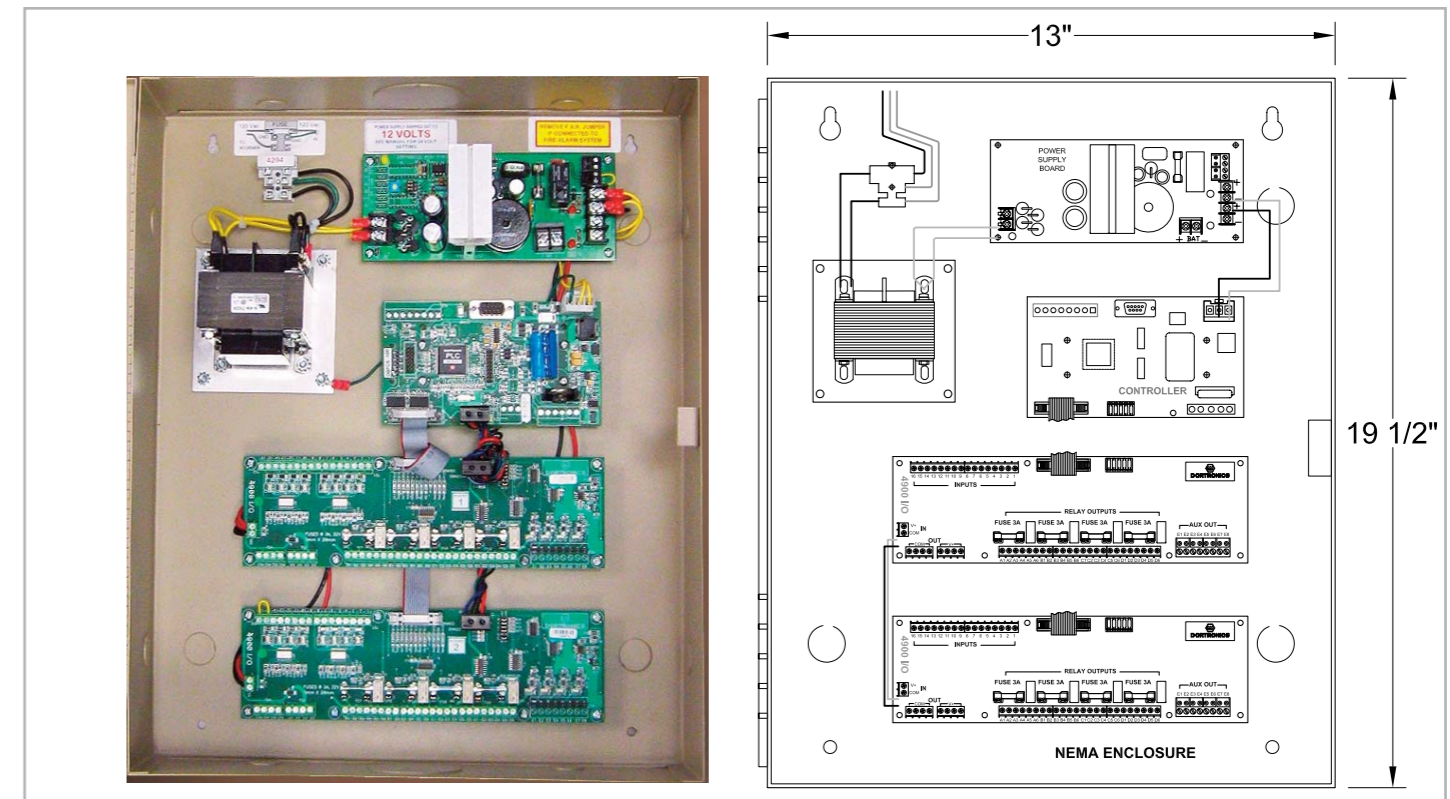

Selecting the Proper Interlock Controller

The required number of inputs and outputs will determine the mantrap model that must be specified. The number of doors, types of doors and other monitored and/or controlled devices must be considered. While totally independent mantraps can be controlled from a single PLC controller, the separation distance of the doors to be controlled can limit the number of doors per controller. Dortronics offers free consultations to assist in the selection of the proper interlock control.

If a number of 2-door mantraps are in close proximity, multiple 4300 or 4700 relay modules can be factory mounted in a single enclosure to share the same power supply and reduce the wall mounting space.

A single #4900 interlock can be configured and programmed to control multiple independent mantraps with one or more power supplies assembled in a single NEMA enclosure.



Inputs to be monitored for normally locked doors are the door position, latch monitor, maglock bond sensor and the request-for-access device, card access lock relay, local push button or other REX device. Normally unlocked doors require only a door position switch. Other monitored devices could be emergency override stations, tailgate detectors, etc. All inputs must be dedicated dry contacts, not shared with other systems. If required, input devices can be mirrored with PLC relay outputs.



Outputs (relays and powered outputs) can be used to operate the electric locking devices, indicator lights, alarm sounders and to signal other systems (card access, guard station consoles, etc.) A least one output relay is required for each controlled door to operate the electric lock. The lock relay contacts can also be used to signal door access status. If the doors are normally unlocked these indicators would follow the lock status (Red = Locked / Green = Unlocked). When doors are normally locked, most systems utilize traffic lights to indicate when access may be granted or denied (Red = Access denied / Green = Access granted) as doors may be locked awaiting authorization from the card access system. Additional outputs are required to indicate when the door is not currently available for access because another door is in use.

Specifying Interlocking Door Relationships

The first step in designing a door interlock system is to determine the traffic pattern and the door relationships. The following illustrates the design of a 5-door/2-room mantrap with one shared door. This system also incorporates two automatic sliding doors, two normally locked manual swing doors and one normally unlocked manual swing door.

The floor plan of this mantrap indicates doors #507 and #508 allow entry into room #508. Door #509B allows passage between rooms #508 and #509. Doors #509A and #509B allow entry into room #509 from other areas.

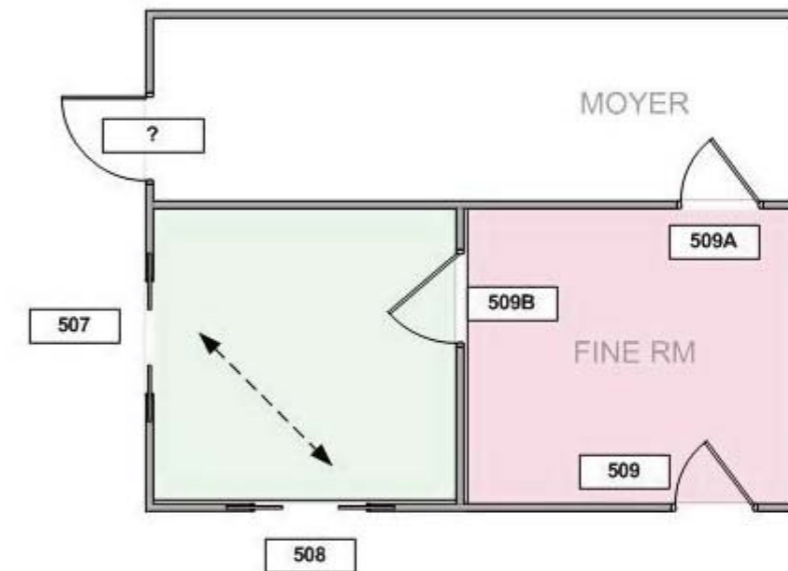

The following chart indicates the relationships between doors. Swinging doors are to be secured with maglocks. The circuit to open the automatic sliding doors will be shunted by the Interlock Controller when they are not available for access.

MANTRAP	DOOR	FROM - TO	DESCRIPTION	WHEN UNSECURED INHIBITS:
#508	#507	Room #508 to Unprotected Area	Auto Door (Inhibited by Interlock Controller)	#508 & #509B
#508	#508	Room #508 to Unprotected Area	Auto Door (Inhibited by Interlock Controller)	#507 & #509B
FINE ROOM #509	#509	FINE Room #509 to Unprotected Area	Single Swing Normally Locked	#509A & #509B
FINE ROOM #509	#509A	FINE #509A to MOYER	Single Swing Normally Locked	#509 & #509B
FINE ROOM #509	#509B	Room #508 to #509	Single Swing Normally Unlocked	#507, #508, #509 & #509A

Use a matrix table, similar to that above, to describe door relationships and specify locking conditions. Also include an explanation of any controlled operations other than lock control. These can also denote air exhaust systems, alarm sounders, etc.

Specifying Door Interlock Systems

General operation:

Mantraps consist of one or more rooms with two or more electronically lockable doors. If any door into or out of a designated area is open or unsecured all other doors in this room are to be locked and prevented from being opened.

Specify interlocked doors & controlled rooms:

Are doors all in one room?

Number each door for reference.

Use a letter designation for each room for reference.

Designate linked rooms with shared doors.

Use existing labels if project plans have unique markings for rooms and doors.

Try to obtain a floor plan if possible for systems with more than three doors

Indicate doors that are inhibited by what

Are there automatic doors or gates to be controlled:

Do the doors or gates re-close automatically after opening or will there be separate open and close switch controls?

Does the door/gate operator utilize built-in switches to limit door travel? Can a "door open" switch be closed to cause the door to stay open indefinitely?

Are doors normally locked or unlocked?

Designate normal status of each door:

How are doors secured? (Maglocks, electric strikes, electrified locksets.)

How are doors monitored? (Door switch, magnetic bond sense.)

How are locked doors accessed? (Card reader/keypad, push button, etc.)

Are traffic lights required: (Confirm operation)

Lights reflect the status of each door lock –

Door Locked Light=RED

Door Unlocked Light=GREEN

This operation uses the lock relay contacts to operate LED indicators

Lights indicate traffic permission –

Door Available Light=GREEN (Door locked or unlocked)

Door Inhibited Light=RED (Door locked)

This operation requires a relay to control the door lock and a separate relay to operate the traffic signals

Three color traffic lights –

RED=No Entry

AMBER=Locked but Available for Authorized Access

GREEN=Door Unlocked for Immediate Access

This operation requires two traffic light relays per door in addition to the lock control relay

Are inputs normally closed or normally open?

Door Status Monitoring:

Door Position Switch = Switch closed when door is closed (Used with normally locked or normally unlocked doors)

Magnetic Bond Sensor = Contact closed when door is secured (Closed and locked – Used with normally locked doors only)

Specifying Door Interlock Systems

Request for Access:

Card Access Relay or Push Button = Normally open contacts close for request to access (Door lock state follows REX input)

Delayed Door Relock = Does REX input have time delay built-in to allow user to pull door open during unlock period? If the card access system or the REX push button does not include an adjustable timer, then an AT timer should be added to the interlock controlled output or add the optional LED display module to the PLC controller

Other Monitored Devices:

All Inputs = Dedicated dry contacts

Specify Operation and Normal Status = Normally open or normally closed

Typical monitored devices = Emergency door release, on/off switch for special systems, etc.

How should emergency override be handled?

Can the fire alarm relay on the power supply be used to unlock maglocks?

If electric strikes are used, will they require power to unlock in an emergency?

Are local emergency release stations required in the mantrap rooms?

Specify input status: NC or NO

Are alarm outputs required if more than one door is open/unsecured in a mantrap room?

Are security alarm sounders required at the doors?

Are alarm outputs required for remote monitoring? (7600 Console)

Are special logic or timing sequences required?

Misting/wash-down room (lock-down with timing function)

Door Held Open Alarm : Use 7281-EA or 7286-PT

Will a security console be required?

Does the remote control panel override interlock rules?

Are door status indicators required?

4300 Series Relay Inputs & Outputs:

Six inputs each (used for door switch, REX, other trigger devices)

Four DPDT relays each (used for door locks, LEDs, alarm sounders & special device control)

4700 Series PLC Module Inputs & Outputs:

Six inputs each (used for door switch, REX, other trigger devices)

Four DPDT relays each (used for door locks, LEDs, alarm sounders & special device control)

4900 Series PLC Module Inputs & Outputs:

Eight inputs each (used for door switch, REX, other trigger devices)

Four DPDT relays each (used for door locks, LEDs, alarm sounders & special device control)

Four digital outputs (12 VDC power @ 1 amp used to power additional relays or drive similar low voltage devices)

The xRLY Relay Expansion Board can be supplied to utilize the four digital outputs to provide four relay outputs configurable as normally open or normally closed.

Additional isolation relays may be supplied to control equipment with high voltage requirements or excessive current draw. (Contact factory for additional information)

Mantrap Application Solutions -

2-Door Cleanroom Airlock with Material Alert Indicator – Used in a testing laboratory application, this 4700 system used two normally unlocked doors with a light to indicate when materials to be tested were left in the airlock. The system allows access through Door-1 anytime Door-2 is closed. Opening Door-1 secures Door-2 and activates indicator light. Personnel can unlock door-2 by push button-1 (in airlock) if door-1 is closed or reverse passage and exit vestibule through door-1. Door-2 can be unlocked for access by push button-2 (outside vestibule at door-2) if door-1 is closed. Opening door-2 locks door-1 and resets indicator light if illuminated.

2-Door Healthcare Interlock – A hospital utilized the Dortronic Systems relay mantrap controller to limit access into the mental health floor. A vestibule with 1100 series maglocks, magnetic bond sensors and door switches on interior and exterior doors secured the area entry. Authorized access is controlled through 5141 key switches on each side of the secured doors. The interlock controller prevents the second door from being unlocked while the first door is unsecured. A #7286-PT door prop alarm is also used at the doors to insure each is re-secured after an authorized access. Doors are also monitored by a #7600 annunciator/controller, located at the nurse's station to alarm if the doors have not been properly re-secured in the allotted time period.

Dual 2-Door Interlock for Bank Lobby – The #4700 PLC controller is used in a bank entry to secure the lobby vestibule with a metal detection unit. This system allowed entry through the exterior door but prevented the interior vestibule door from opening if the metal detector is triggered. Entry from the exterior was inhibited through the outside exit door. The interior exit door was normally unlocked for free egress unless the outside exit door was open.

Complex Multi-door Casino Interlocks – Money counting areas in casinos require the high security afforded with mantraps to secure and maintain separation of money counting areas. Some projects may use multiple independently controlled mantraps with two, three or four doors each, while others have required several shared doors between adjoining secure rooms. Projects with over thirty interlocked doors are not uncommon for these facilities.

Armored Car Facilities – These facilities utilize door interlock controls to secure vehicle doors or gates in addition to pedestrian doors. Each facility will have their own unique requirements but all will incorporate both card access and remote guard console control. The interlocking door system must also be capable of controlling doors with electric locks and automatic door operators. Most systems also require indicator lights for user feedback. The guard console switches can signal a request for access while console LEDs provide door status indication.

Embassy Door Interlock – This 4900 series multi-door system was designed to secure entry/exits of a secure facility with five normally locked doors in three interconnected rooms. Ingress was limited by key switch / LED stations and maglocks with REX push buttons to provide egress control. Emergency pull stations were specified to allow override of the system in an emergency.

Mantrap Application Solutions -

Insecure Airlock Systems – Sometimes local code requirements may prohibit the automatic locking of corridor doors. These systems depend on management enforced procedures to maintain sterile conditions. When allowed, delayed egress controls can be incorporated into the interlock system to allow egress in an emergency but normally operate in the secure mode. If no locking devices are permitted, then traffic lights can be used to signal access permission with local alarm sounders to designate violations.

2-Door Sterile Interlock with Special Air Handler Controls – This system was used in a biological testing lab with a 4700 series controller to lock and unlock two doors and operate air damper vent controls. Technicians open unlocked door-1 to load toxic material into mantrap and sterilization is activated by push button. System inhibits locked door-2 and locks door-1 before damper control activates exhaust for a timed cycle. The controller initiates a second sterilization cycle after a programmed time period to unlock door-2 for removal of items while door-1 remains secured. System is manually reset by push button for another cycle. Hi-intensity LEDs are also used to indicate operations.

High Security Sallyports – Dortronic Systems PLC systems are also used to operate vehicle gates into and out of secure areas. Double gates are used to allow only one authorized vehicle access at a time. Vehicles passing through the first gate are tracked and the second gate can only be opened after the first gate has closed behind the vehicle. Sensors keep the gates from closing before the vehicle is clear and hi-intensity LED traffic lights direct drivers through the sallyport. Gates can also be remotely operated and monitored by the CCTV system.

Laser Test Facility Interlock – This multi-door system required varying door control operations dependent upon activities within the facility. In normal operation doors were secure with standard card access ingress/egress and material pass-through portals are accessible. The interlock mode, which could be initiated from various station controls, locked and inhibited some doors and activated a door interlock operation for other designated doors and pass-through portals were shut and secured. This system also used a key switch to temporarily override the interlock mode.

Interlocks with Purge Delay – These two, three and four door, one room interlocks were configured to have two individually adjustable timing sequences for each interlock area in a pharmaceutical manufacturing facility. All doors into each interlock were normally locked with maglocks and traffic lights controlled by the PLC. An authorized request for access, when other doors are secure, will inhibit other doors and activate the purge time delay. At the end of the purge cycle the PLC unlocks the door for the time delayed relock period. Once the access door is closed and relocked, the inhibited doors remain secure but are made available for authorized access. Hi-intensity LED traffic lights are used to indicate when access is permitted.

Courthouse Security Interlock – This project used a 4900 IDC to segregate the public from the secure areas. The complex system incorporated card access entry, electro-mechanical egress hardware, key switch overrides, emergency delayed egress and custom alarm functions.

1100 SERIES ELECTROMAGNETIC DOOR LOCKS



650 / 1200 / 1500 Pounds
Holding Force

Shallow 2" Mounting Profile

Field Selectable 12/24 DC
Voltage

Low Current Draw

These electro-magnetic locks provide positive, instantaneous door control. Available for inswing, outswing and sliding single or paired doors. Filler plates, angle brackets, and custom mounting hardware are available in architectural finishes to compliment any decor. Maglocks are inherently failsafe, releasing instantly upon command or loss of power and have no parts to wear.

3300 SERIES ELECTRIC STRIKES



Field Selectable Fail-Safe or
Fail-Secure

Universal Operating Voltage
12 to 24 VDC

Continuous Duty Operation

Heavy Duty Stainless Steel
Latch Jaw

3300 Series electric strikes are supplied with both an ANSI strike plate for metal frames and an 8 inch tall strike plate for wood or special installations. Simple field adjustment will convert these strikes from fail-secure to fail-safe operation. The power converter, supplied, allows operation from any 12 to 24 volt DC power source. Optional latch sensor provides a form C output to indicate secure or unsecure door status.

3400 SERIES ELECTRIC DROP BOLTS



Suitable for Herculite Doors

Automatic Alignment Sensor
& Adjustable Timed Relock

Fail-Safe 12 VDC Operating
Voltage

Heavy Duty Stainless Steel
Bolt

3400 Series electric drop bolts provide reliable mechanical locking, they can be used on single acting inswing or outswing doors or double acting doors. The optional U-bracket allows for mounting on Herculite doors. The Automatic Alignment Sensor activates the bolt upon detecting proper alignment with the receiver plate.

The time delayed relock is selectable in increments up to 9 seconds.

5210 SERIES MUSHROOM & KEY RESET BUTTONS



1-9/16" or 2-3/8" Diameter
Button

Momentary, Alternate
Action or Time Delayed

Optional Latching with
Key Reset Function

The 5210 request-to-exit controls are ideal for use in hospitals, industrial complexes, office buildings and institutions to release electric door locks

Dual contact blocks, 1-NO & 1-NC, allow the magnetic lock power to be cut by the normally closed contacts while simultaneously signaling other systems with the normally open contact. Bi-Color LEDs are available for status indication.

5276 WR SERIES WATER PROOF SWITCHES



Suitable for Washdown
IP65 Rated

Optional LED Indicator
Ring

Heavy Duty Vandal proof
Flush Mount Design

The WR5276 heavy duty stainless steel Switches are ideally suited for rooms that require washdown. They are rated IP65 to withstand water spray from any angle. These units feature an optional red/green LED illumination status ring which is independently controlled and ideal for indicating door or lock status. Control automatic doors, electric strikes or magnetic locks or use the DPST contacts as a (REX) input for an access control system.

5277 SERIES PIEZOELECTRIC SWITCHES



Heavy Duty Stainless
Steel Button and Plate

LED Status Indicator

Adjustable Time Delayed
N.O. & N.C. Contacts

Weather Proof Design

The 5277-PZL stainless steel Piezo Switches are ideally suited for heavy usage applications. These units include a selectable on/off switch, red/green LED illumination status ring and an adjustable time delay of 1 to 40 seconds. Uses include control of automatic doors, electric strikes or magnetic locks or as a remote (REX) input of an access control system. The Touch Sensitive button has no moving parts. Weather proof design for outdoor applications

5278 SERIES TOUCHLESS SWITCHES

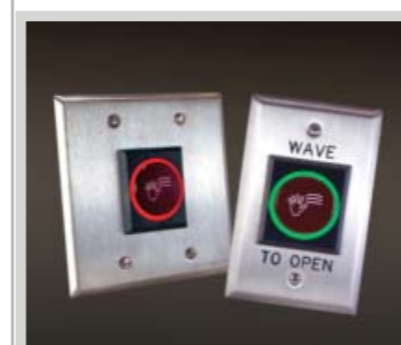

Touchless Activation

LED Ring Status Indicator

Momentary Pulse DPDT
Output

Environmentally Sanitary

The 5278 series provides an economical solution for Touchless Ingress/Egress. The 5278 utilizes Optical Infrared Technology. The imbedded sensor picks up motion within a 4 inch range of the face plate. A simple wave of the hand activates the switch. The 5278 greatly decreases the potential to spread contagious diseases since no actual hand contact is required to activate.

5287 SERIES HEAVY DUTY BUTTONS



Impact Resistant Metal
Construction

Deflecting Guard Ring

Easy Operating Actuator
Button

Hard Anodized Finish

Designed for hard use applications, the 5287 heavy duty push button is suited for installation in environments where it may be impacted by rolling carts or loaded warehouse wagons. Engineered to absorb direct force impact and deflect side blows, the pushbutton's rounded form also prevents snags on passing pedestrian traffic. The 5287 switch's 1-1/2" diameter solid aluminum button is housed in a protective beveled aluminum guard ring.

6500 SERIES EMERGENCY PULL STATIONS



Highly Visible in Black, Blue, or Yellow

Emergency Door Release

Deters Unauthorized Entry and Exit

Dual Switch Contacts

Emergency Pull Stations are stocked in black, yellow and blue to clearly differentiate them from traditional "red" fire alarm stations. These door pull stations mount to a 1-gang box. Also offered is a matching color back box. The 6510 can be reset with the supplied key and by replacing the unit's acrylic break rod (1 supplied per unit for tamper detection).

7201 SERIES HI- INTENSITY LEDs

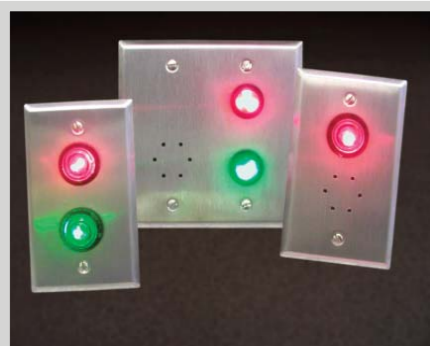

Highly Visible Daylight Viewing

Ideal for Traffic Indication

Sealed for Exterior or Interior Applications

Optional Piezo Sounder

7201 Series High Intensity LED Indicators are available in a variety of configurations for outdoor and indoor use. Weatherproof High Intensity LEDs & Piezo sounders are supplied on a gasketed plate for exterior applications. Basic units feature high intensity red and green LEDs on a single plate for mounting in a standard electrical box to interface with virtually any type of access control system.

7286 SERIES DOOR PROP & EXIT ALARM



Local Exit Alarm or Door Prop Alarm

Adjustable Door Open & Alarm Warning Time

Manual & Automatic Reset

Optional Key Switch Reset or By-pass

The 7286-PT Prop Timer has a bi-color LED to indicate door status, an audible alarm sounder and a mirrored door switch output. It also has pass through low voltage DC power output to operate a locking device. A signal from an access control panel prompts the panel to unlock the door. The door open time, and the local warning time are adjustable.

7000 SERIES ANNUNCIATORS & CONSOLES



Control, Doors, Gates Mantraps, & Sallyports

Designed to fit your requirements

Specify the configuration & we'll build it

Used in government, medical, law enforcement and detention facilities, custom control panels & consoles are constructed using any combination of heavy duty switches, audible sounders and LED indicators. Components can include relays, intelligent logic or simply wire leads. CAD is used both for design and fabrication of these high security panels where quality, reliability and durability are critical.

DORTRONICS SYSTEMS, INC.

A division of SAG HARBOR INDUSTRIES

Driven by new product development and customer service

Charles Edison, the son of inventor Thomas Edison, founded Sag Harbor Industries in 1945. Sag Harbor Industries is a contract manufacturer of custom electronic assemblies. Products manufactured in the Sag Harbor, NY and Farmville, NC facilities include motor windings, solenoids, stators, voice coils for headsets and printed circuit board assemblies. Satellite communication gear and Medical sub-assemblies are also produced in a controlled environment.

In 1989, Sag Harbor began producing electromagnetic locks for Dortronics Systems. Dortronics Systems was purchased and became a wholly owned subsidiary of Sag Harbor Industries in 1990. Dortronics Systems operates out of the Sag Harbor Industries facility on Long Island and manufactures electric locking hardware and controls for the Security, Hardware, and Door control industries.



We proudly stand behind every one of our products through our customer service, product dependability, and Quality product warranty.



WHAT YOU WANT - WHEN YOU WANT IT

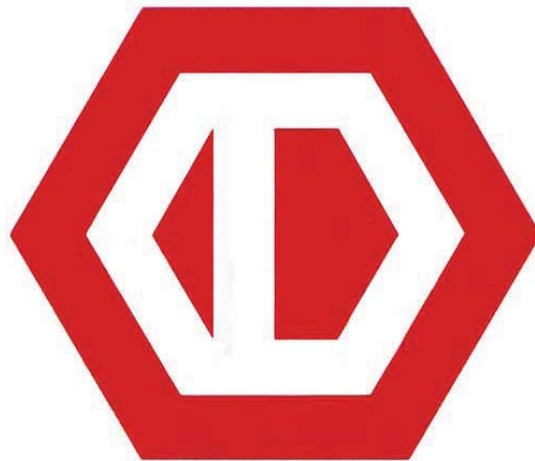

Made with pride



1668 SAG HARBOR TURNPIKE SAG HARBOR NY 11963
www.dortronics.com • (800) 906-0137 • (631) 725-8148 FAX • sales@dortronics.com