

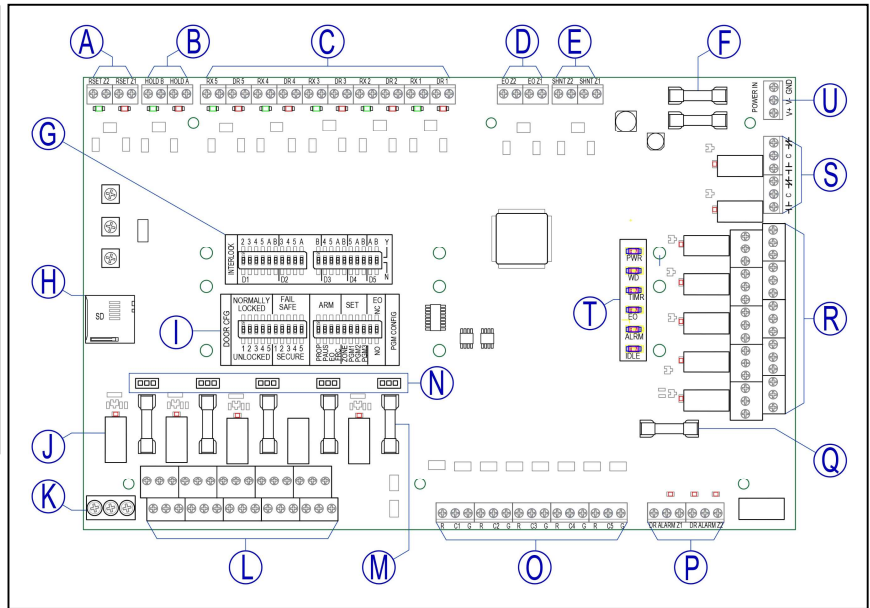

48500-EZ Setup and Operation

The 48500-EZ PLC interlock controller is configured on-site to handle all typical interlock and airlock requirements from 2 to 5 doors. Changes are as simple as throwing a switch. Features include:

- Single zone or two zone operation. Run two independent mantraps from a single controller.
- Program changes and system configuration by switch and jumper. No programming experience needed.
- Set each door for normally locked or unlocked, powered or unpowered, fail safe or fail secure operation.
- Two A & B HOLD inputs to deny access for out of limit condition or scanner alert. Two A & B HOLD outputs.
- The A & B inputs and outputs can be used to tie more than one 48500-Z together to control more than 5 doors.
- Three adjustable timers are available to set limits on doors propped open, timed emergency unlock, or to inhibit doors after use to allow air pressure equalization.
- The system comes in a lockable metal enclosure with a 4 Amp power supply. It can be ordered without either.



- | | | | | | |
|---|--------------------------------|---|-----------------------------|---|---------------------------------|
| A | Reset – Silence Alarm | H | SD Card Slot | O | Red-Green Traffic Light Outputs |
| B | HOLD A & B Inputs | I | Door Configuration Switches | P | 2 Zone Door Alarm Outputs |
| C | Door and Access Control Inputs | J | Lock Control Relays | Q | LED Output Fuse |
| D | Emergency Override Unlock EO | K | Board Ground – Lock Return | R | Door Status or ADO Outputs |
| E | Shunt Interlock by Zone | L | Lock Control Outputs | S | HOLD A & B– Outputs |
| F | Main Fuse | M | Lock Power Fuse 2 Amps | T | System Status Lights |
| G | Interlock Set Switch Block | N | Lock Output Wet Dry Select | U | Power In 12-24 VDC |

TOPICS

OVERVIEW	PAGE 3
QUICK START	PAGE 3
MOUNTING & WIRING	PAGE 4
SINGLE OR DUAL ZONES	PAGE 5
DOOR ALARMS	PAGE 5
FUSES	PAGE 5
FACTORY DEFAULT SETTINGS	PAGE 6
INTERLOCKING DOORS	PAGE 6
FAIL SAFE OR FAIL SECURE LOCKS	PAGE 7
WET OR DRY RELAY CONTACTS	PAGE 7
TRAFFIC LIGHTS	PAGE 7
USING ZONES	PAGE 7
USING TIMERS – DOOR PROPPED, TIMED EO, AIR MAKEUP	PAGE 8
USING ADO MODE	PAGE 8
USING ZONES	PAGE 9
USING A & B HOLD AND LOCK	PAGE 10
CONNECTING MORE THAN ONE 48501-EZ TOGETHER	PAGE 11-12
FORCED DOOR ALARM DISABLE	PAGE 14
SHUNT THE INTERLOCK – 1 OR 2 ZONES	PAGE 16
USING ONE-WAY LANES	PAGE 14-15
WET OR DRY ALARMS	PAGE 15
AUTO DOORS WITH LOCKS	PAGE 17
OPTIONAL SETTINGS	PAGE 16
TROUBLE SHOOTING - SYSTEM STATUS LIGHTS	PAGE 18
EXAMPLES	PAGE 19 – 20
TECHNICAL INFORMATION	PAGE 20

OVERVIEW

The 48500 EZ is a single board solution for interlocking doors in various facilities such as clean rooms, sally ports, test labs, materials air locks, data centers, cash rooms, nursing stations, vehicle lanes, and school security. The system may be configured onsite for door control, alarm response, security level, and system overrides by setting switches to best meet local requirements.

The controller is capable of two-way communication with exterior monitoring equipment, remote guard console, or other controllers.

The controller can source lock power or switch power by others. It can signal an automatic door operator. Dry contact switches report door status and interlock violations to access control. Traffic light outputs indicate access status.

System status annunciator lights along with LED indicators for input and output status verify correct wiring and program operations at install and for subsequent troubleshooting.

Three adjustable onboard timers can be set to delay door use for pressure equalization, alert on a propped open door, or provide a timed emergency unlock period.

Single or dual zone operation.

Operation of two, one-way entry or exit lanes with automatic doors or gates, with connections for external tailgate alarms, metal detectors, or external lockdown commands.

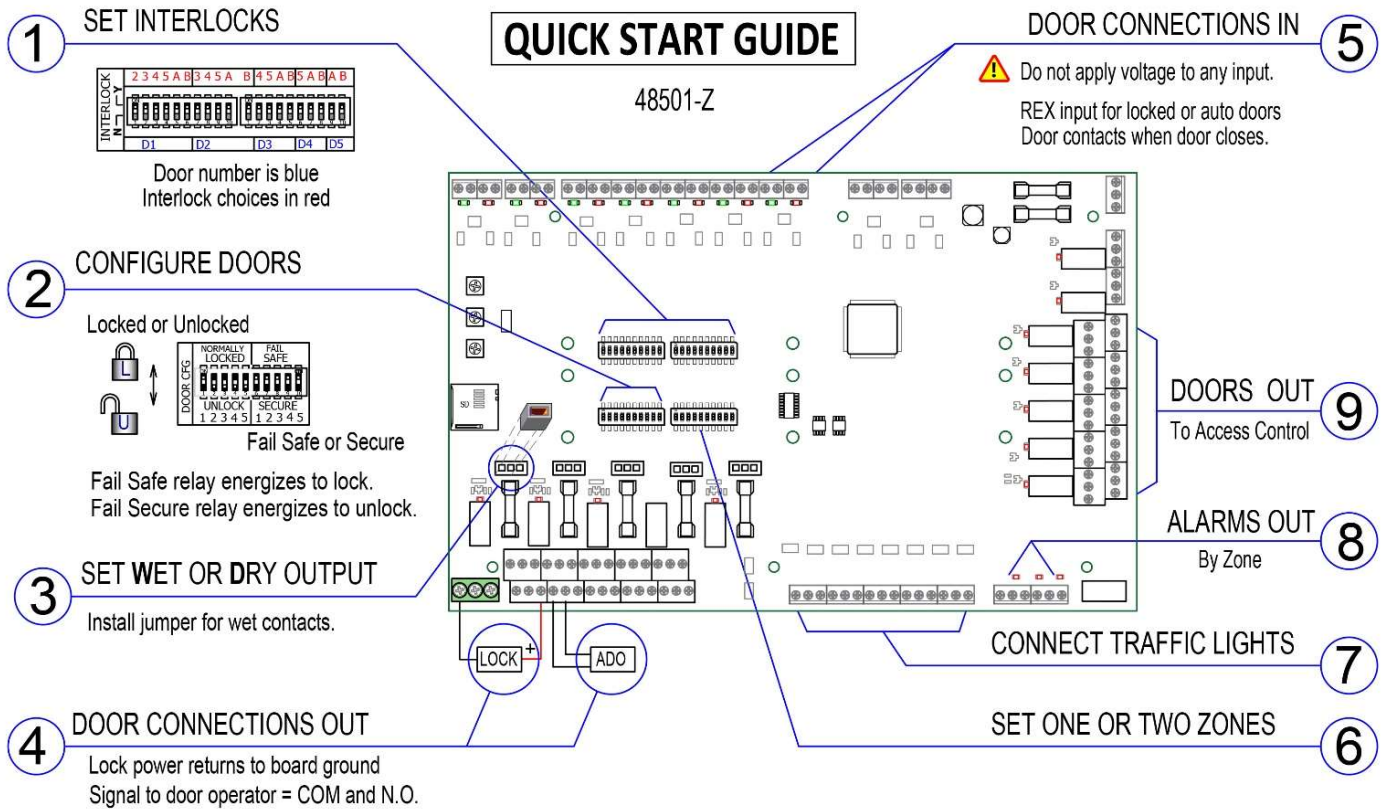
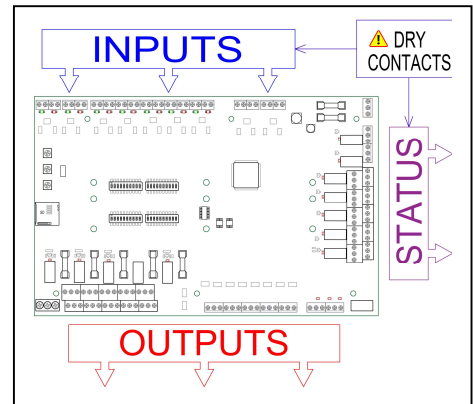

MOUNTING & WIRING

DIN RAIL OR STANDOFFS

Mounting the board in the enclosure is by DIN rail clips or standoffs.

The DIN rail allows the installer to make most of the wire connections with the controller out of the enclosure. When connections are complete, the controller snaps onto the track. Use a small screw driver to unclip the controller. Insert driver through DIN clip release opening. Engage the slot, press down and away to release the clip. Repeat for each clip.

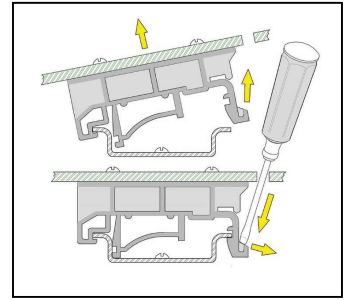

WIRING

1. INPUTS - Shielded or twisted pair 22 to 18 Gauge.

Do not mix common and signal wires, especially when making inter-board connections or wiring parallel inputs.

2. LOCK POWER - 18 to 16 Gauge wire.

3. LEDs & SOUNDERS - 20 to 18 Gauge.

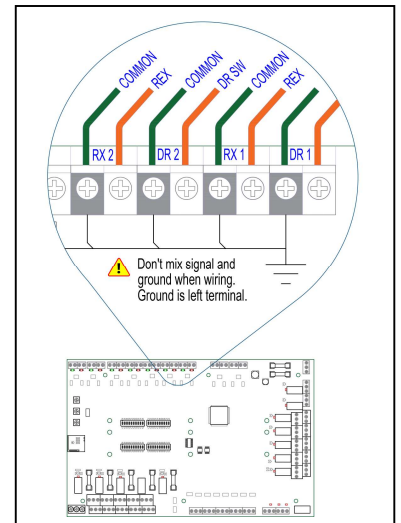

DOOR POSITION SWITCH (C)

Door switch contacts close when the door closes lighting the door input LED.

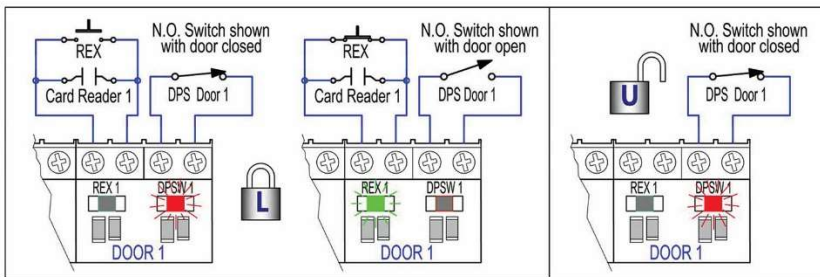

ACCESS CONTROL INPUT (C)

Connect access control output to the REX input - card reader, motion detector, wave switch or similar device.

Normally unlocked doors don't use the REX input. Normally locked doors must have a REX input to unlock.

LOCK OUTPUT (L)

The lock relay switches lock power. *When using wet contacts, lock ground return connects to board ground.*

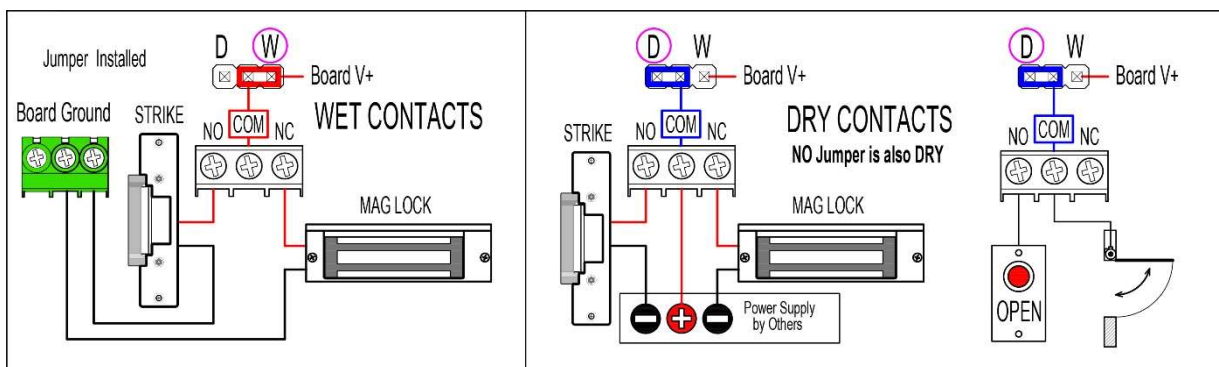

CONNECT DOOR LOCKS (L)

Lock relays (L) are **DPDT**. The primary set of contacts are fuse protected and can power locks directly (wet), or used dry. Secondary contacts are dry contact only.

Install a jumper in the W position for wet contacts - supply V+ applied to relay common. Move to the D position or remove the jumper for dry contacts.

Relay contact rating 2 Amps at 30 VDC.

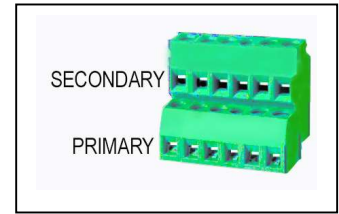

LOCK OUTPUT FUSES (M)

If a fuse blows, correct the cause of the overcurrent before replacing.

Use the correct quick blow fuse rated for 2 Amps.

CONNECT TRAFFIC LIGHTS (O)

The Traffic Light outputs with fuse protection are powered for direct connection to LEDs.

Do not short any powered output.

Traffic lights for unlocked doors indicate lock status; green for unlocked and red for locked.

Traffic lights for locked doors, indicate door availability; green for available, red for not.

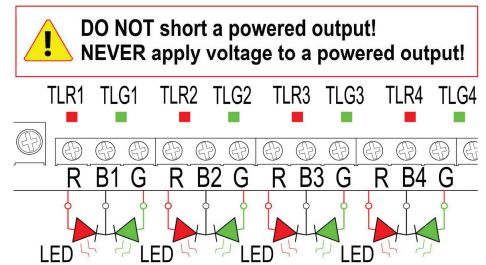
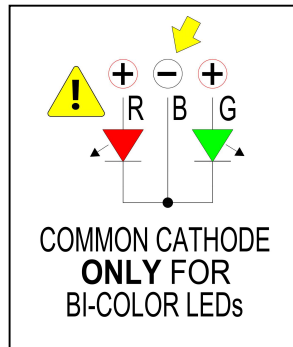
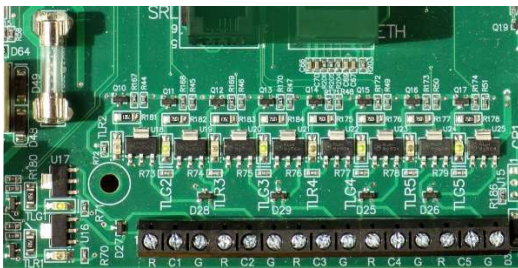
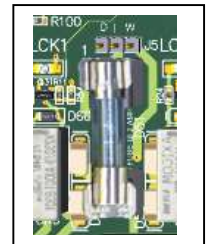

RELAY INDICATOR LED

An LED indicates when a relay energizes.

DOOR ALARMS (P)

Two wet/dry relay Door Alarm outputs are provided – one for each zone. If the system is configured for a single interlock, only the door alarm for zone 1 is enabled. Relay energizes when:

1. Two interlocked doors open.
2. A forced door (open without valid REX) – this alarm may be disabled.
3. A door is propped open past a set limit – this alarm must be enabled.
4. A door interlocked to HOLD input opens with an active hold.
5. In Lane mode, if a tailgate or threat alarm activates or for interlock fault.

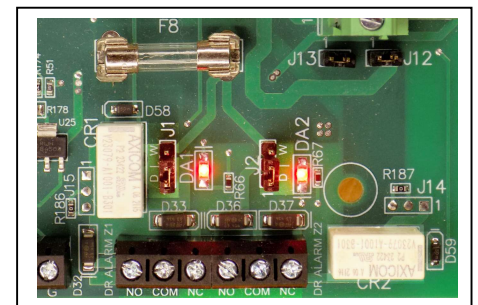

CONFIGURATION SETTINGS

FACTORY DEFAULT SETTINGS – AS SHIPPED

- Doors 1 and 2 are interlocked. Door inputs for 3, 4 and 5 are jumpered.
- One zone
- Fail Secure
- Dry contact lock output
- Normally unlocked
- All timers off
- Forced Door alarm enabled
- EO triggers on closed contacts
- Timer adjustments to minimum value

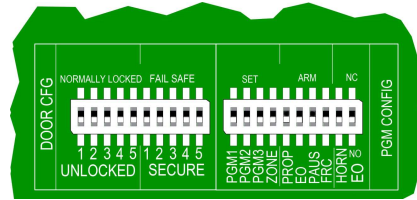

DOOR CONFIGURATION SETTINGS

SET LOCKED OR UNLOCKED OPERATION

Set each door for locked or unlocked operation. A locked door must have a REX input to unlock. Auto doors with a wave switch without locks should be set for locked operation.

A normally unlocked door locks when an interlocked door opens, or if interlocked with an active HOLD input.

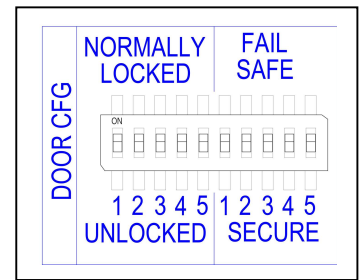

SET DOOR INTERLOCKS

NOTE: if no interlocks are selected, the system status light IDLE light will flash.

Interlocks are reciprocal: if door 1 is interlocked with door 2 then door 2 is automatically interlocked with door 1. Only one switch is used to interlock both doors.

Switches are arranged in blocks by door number. D1 = Door 1, D2 = Door 2 and so on. Above the D1 block are 6 choices, doors 2 – 5 plus A and B. Note that each block has one less choice than the previous block to prevent duplication. D2 block does not include a choice for door 1.

1. Select interlocks for door 1 (blue). Switch up (Y) to interlock.
2. Select doors that interlock with door 2.
3. Select the rest of the interlocks in a similar manner.
4. If no selection is made, that door will not be interlocked. The controller will ignore the status (open or closed) of any door not interlocked with another door.
5. For two zones, doors 1, 2 and 3 always make up zone 1. Doors 4 and 5 always make up zone 2. If door 1, 2 or 3 is interlocked with either door 4 or 5 make sure the Zone DIP switch is off. See Using Zones, below.

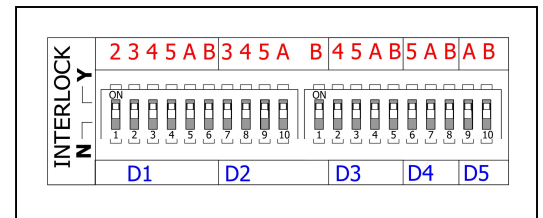

REMEMBER: In two zone operation interlocks outside the zone are ignored. Doors 1,2, 3 can't interlock with 4 or 5

SET LOCK RELAY FOR FAIL SAFE OR FAIL SECURE

EXAMPLE: In the example at the right, Door 1 is locked. All of the other doors are normally unlocked.

All lock outputs are shown **FAIL SECURE** meaning that the relay energizes to unlock the door. Move switch up for **FAIL SAFE** - relay energizes to lock.

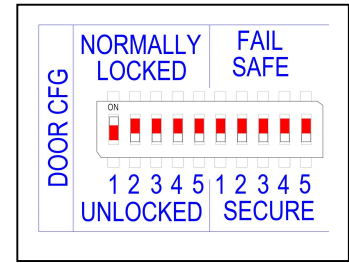

Typically, mag locks are connected to the normally closed relay contacts electric strikes are usually connected to the normally open contacts.

NOTE: some locks can be set for fail safe or fail secure. Make sure the lock setting is correct for the controller setting.

SET WET OR DRY LOCK OUTPUTS

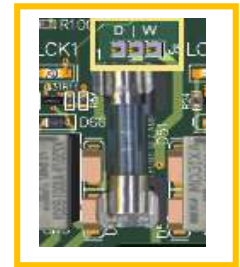
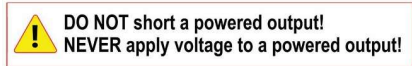

Lock outputs can be either wet (supply positive voltage at the output) or dry (no voltage at the output). Install jumper for wet contacts. **With jumper removed or in the dry (D) position, the output is dry.**

SET EMERGENCY UNLOCK TO TRIGGER ON OPEN OR CLOSED CIRCUIT

The emergency unlock feature (EO) unlocks all doors regardless of interlock status for as long as the input is true.

EO can trigger on an open circuit (NC) or closed (NO).

For pull boxes or similar connected in **series** use **NC**

For pushbuttons, or alarm circuits in **parallel** use **NO**

The EO system if used should be periodically tested to ensure readiness.

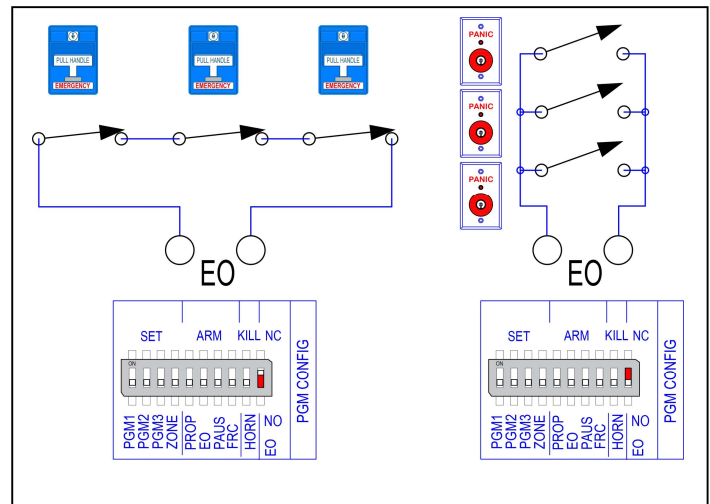

SET WET OR DRY ALARM OUTPUTS

There are two door alarm relays. They can be used to power sounders, strobes, or other powered indicators directly by installing the wet output jumper. For dry output to signal other monitoring stations remove the jumper.

The **Door Alarm** relay is energized if a locked door is open without a valid REX (forced door) if two or more interlocked doors are open at the same time, or if a door is propped open when the door prop alarm timer is set.

The **forced door alarm** may be disabled by moving the **FRC** switch to “SET”. This should be done for doors with card reader in and mechanical release exit such as a crash bar or electric strike lever unlock.

PROGRAM CONFIGURATION SETTINGS

TIMER FUNCTIONS

There are three analog timers provided: **PROP**, **EO** & **PAUS**.

PROP is a propped door timer. Door alarm sounds if a door is open past the set time limit.

EO is a timed emergency unlock feature that unlocks all doors for an adjustable time.

PAUSE locks doors briefly after use for air makeup. Locked time is adjustable.

ARM/DISARM TIMER FUNCTIONS

Timers have to be armed before they can be used.

Move the DIP switch to the ARM or SET position to enable a timer.

ADJUSTING TIME DELAYS

There are three rotary controls to adjust the time value. Use a small screwdriver to rotate the control clockwise to increase the delay and counterclockwise to decrease.

DOOR PROPPED OPEN TIME 15 SECONDS TO 5 MINUTES

Adjust the allowed open time by turning the rotary control labeled PROP. When armed, any interlocked door open beyond the set time energizes the door alarm relay. The traffic light blinks red.

EMERGENCY OVERRIDE TIMED UNLOCK 15 – 120 SECONDS

When armed, the EO timer unlocks all doors for the time delay set using the rotary control.

The emergency override has precedence over interlocks and holds.

PAUSE TIME 1 SECOND TO 45 SECONDS

The PAUSE timer keeps interlocked doors locked after a door has been used:

- For air pressure equalization
- For door seal inflation
- For mechanical lock engagement.

NOTE: *PAUSE* timer does not monitor air parameters. Use the *HOLD* feature to monitor an out of limit alarm from other systems. See below.

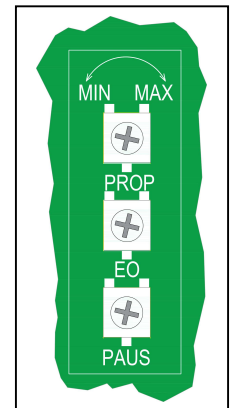
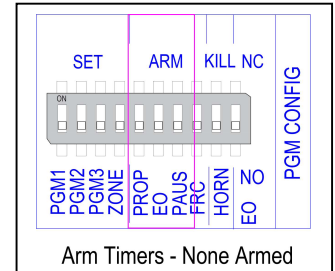

USING ADO MODE – PGM1

Note: Normally unlocked automatic doors with a lock can use the secondary lock relay contacts to interrupt the OPEN request circuit when the door locks.

For normally locked automatic doors with locks, where doors should **not** open in an emergency unlock (EO) until requested, use ADO mode.

ADO mode converts the door position status relays into open signals for the operator.

The open signal is delayed a fraction of a second to ensure that the lock is disengaged to prevent binding.

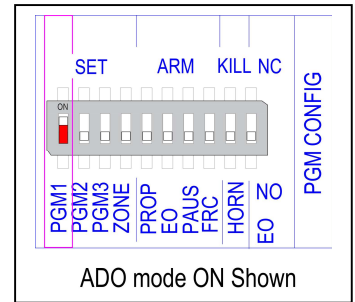

CONSIDERATIONS

- Lane Mode can not be used with ADO mode.
- The violation tracking feature is disabled in ADO mode.
- Doors remain closed when the emergency override (EO) is active until requested (active REX input).
- For access control door status, either DPDT door switch, or external relay must be used to provide door status to the 48501-EZ and access control.
- ADO mode can not be used exclusively for just one zone.
- Some door operators sequence unlock and opening with a single input.
- The emergency override release is separate from the Fire Alarm input on the power supply that kills power to the system.
- Local fire and safety guidelines may apply.

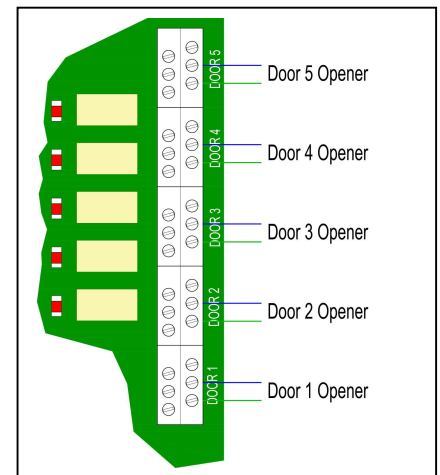

USING ZONES

IMPORTANT: When two zones are selected, interlocks between the zones are ignored. To interlock doors 4 or 5 with doors 1, 2, or 3, zone switch must be off (down).

The 48501-EZ may be used to control up to five doors in a single zone, or two completely independent mantraps in two zones. Single zone is the default.

For two zone operation, move the ZONE DIP switch to SET.

Each zone has its own door alarm, shunt and emergency unlock.

Timer settings apply to all doors regardless of zones.

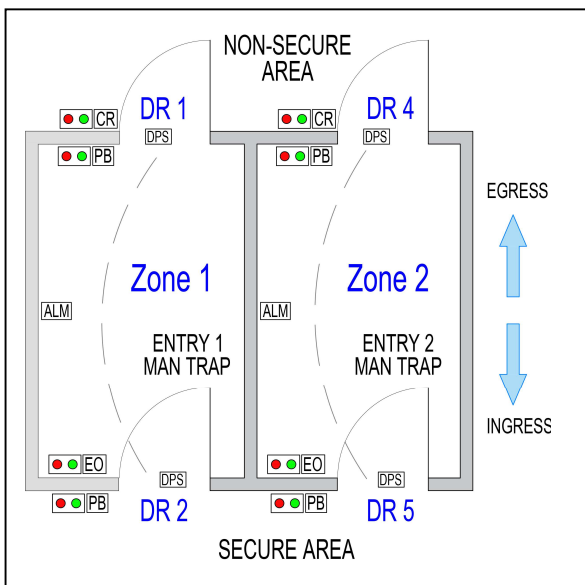
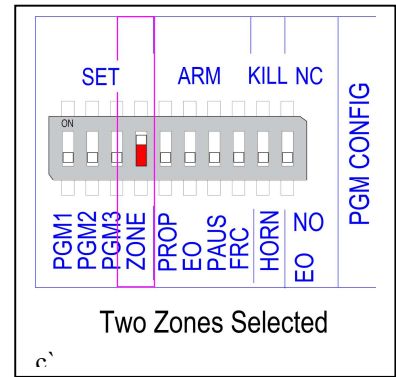

Operate two independent two-door mantraps with a single controller.

Doors 1 and 2 are zone 1.
Doors 4 and 5 are zone 2.

Door 3 is always zone 1.

HOLD A and B can be used to prohibit entry into the secure area for an abnormal condition, such as tailgating, metal detected, air pressure loss.

Each zone has a door alarm and emergency override as well as interlock shunt.

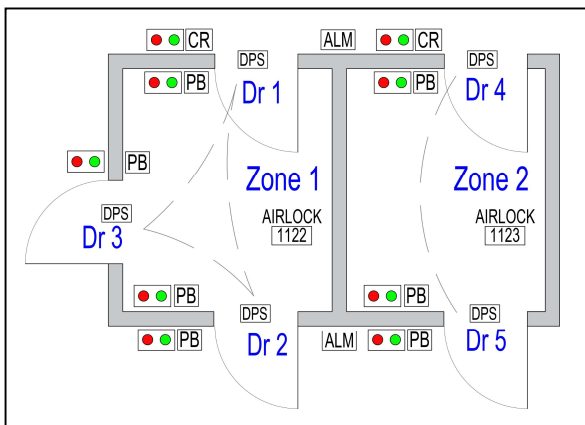
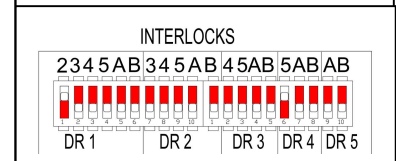
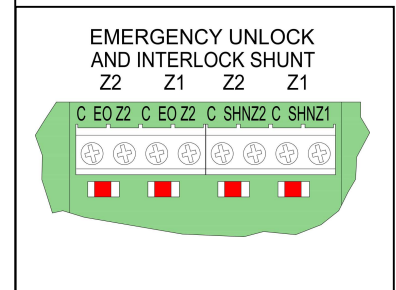

Zone 1 has three doors. Zone 2 has 2 doors.

If door 1, 2, or 3 opens, the other two doors remain locked and unavailable.

Doors 4 and 5 are interlocked.

Each zone has its own emergency override, door violation alarm and interlock shunt.

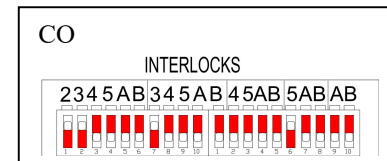
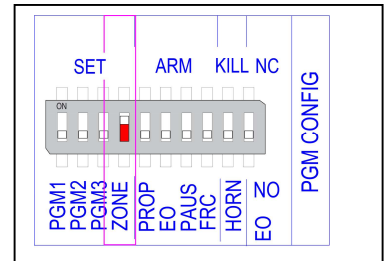

USING THE HOLD FUNCTION

The 48501-EZ hold function allows selected doors to be interlocked with sensors, remote switches or doors from other controllers. Conditions that could require doors to be held secure include:

- Out of limit air parameters for airlocks
- Metal Detector alarm
- Duress Alarm
- Intruder or security alarm
- Washdown
- Secure doors for test safety
- Mantrap occupancy over limit - tailgate alarm
- Connecting two 48501-EZ controllers together to interlock more than 5 doors.
- Guard room override to prevent access.

The door HOLD system consists of two inputs and two outputs labeled A & B.

When a HOLD input is shorted (active) doors interlocked with Hold lock down. Doors may be interlocked separately with HOLD input A or B or with both A & B.

The HOLD A output changes state if any interlocked door is unsecure. HOLD B works the same.

The hold function makes it easy to prevent doors from opening until an abnormal condition is cleared.

Two or more controllers can be connected in parallel to an alarm signal. Do not mix input common and input signal between boards.

NOTE: Emergency Override to unlock all doors takes precedence over all interlocks.

For sallyport and lockup use, when a duress alarm is active, movement through the facility is directed along specific pathways. The hold system makes it easy to lock certain doors while allowing others to be accessed.

The HOLD outputs can be used to interlock doors on more than one controller. See example below.

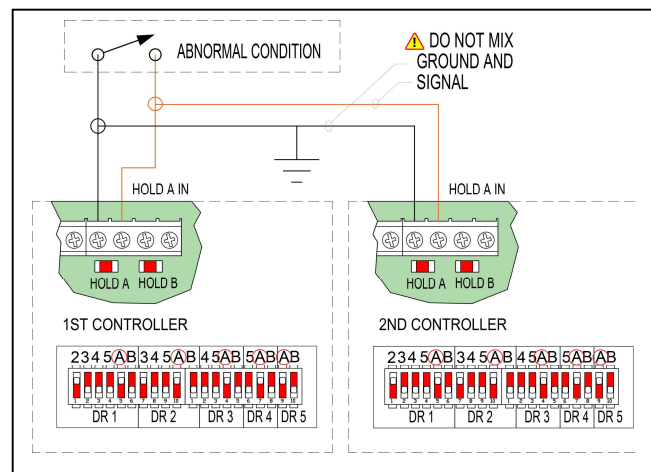

CONNECTING TWO 48501-EZ CONTROLLERS

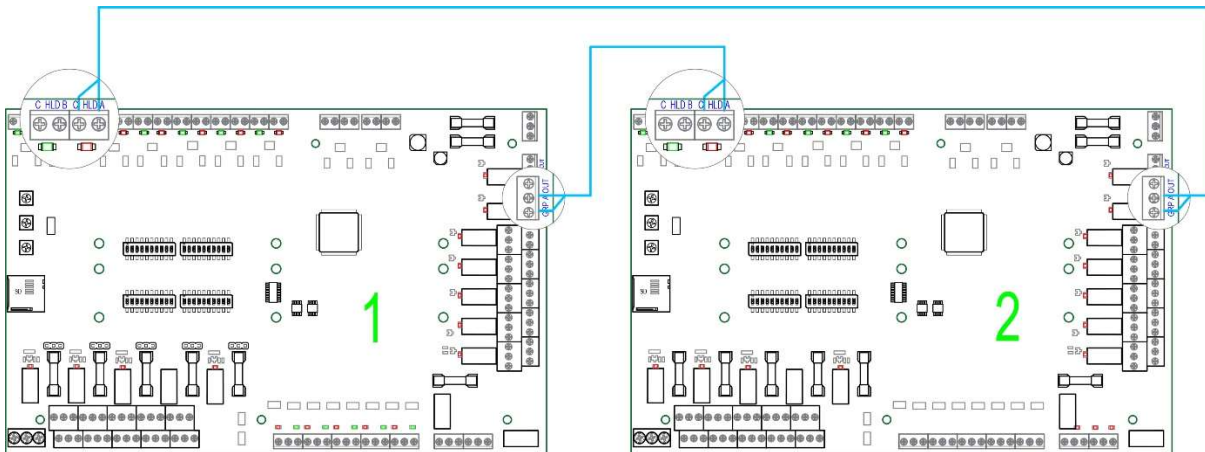

INTERLOCKING MORE THAN 5 DOORS

The A & B HOLD function has both inputs and outputs. These can be used to signal door status to and from other controllers. Access is denied for any door interlocked with HOLD A while the HOLD A input is active.

The **HOLD A output** is active when any door interlocked with HOLD A is open or has an active REX.

HOLD B works the same.

In the example below, three airlocks open into a corridor. Seven doors are involved requiring two 48501-EZ controllers. Door 1012 in the corridor is interlocked with doors M02, P02, Q02. M02 and M01 are interlocked, P02 and P01 are interlocked and Q02 and Q01 are interlocked. Door numbers for the controller interlock switches are in color; pink for controller A and blue for controller B.

The DIP switches for PLC 1 interlock door 1 (M01) with 2 (M02). Door 2 is interlocked with 1 on PLC 1 and also door 1 on PLC 2 (1012) by selecting A.

Door 5 on PLC 1 interlocks with 4 and also door 1 on PLC 2 by selecting A.

ON PLC 1 if door 2 or 5 opens, PLC A output contacts close. These are connected to the A input of PLC 2.

Since Door 1 of PLC 2 is interlocked to PLC 2 A input, It will lockout until doors 2 and 5 on PLC 1 are closed.

The allows for one controller to interlock with one or more doors on another controller using the HOLD function. Since there are two hold inputs and outputs, it is possible to interlock a door to one or more different doors on another controller.

LIMITATION

Board to board interlocks work best when there are only a few doors shared between two controllers. For complex interlock relationships with large groups of doors, specify a 4900 series custom controller.

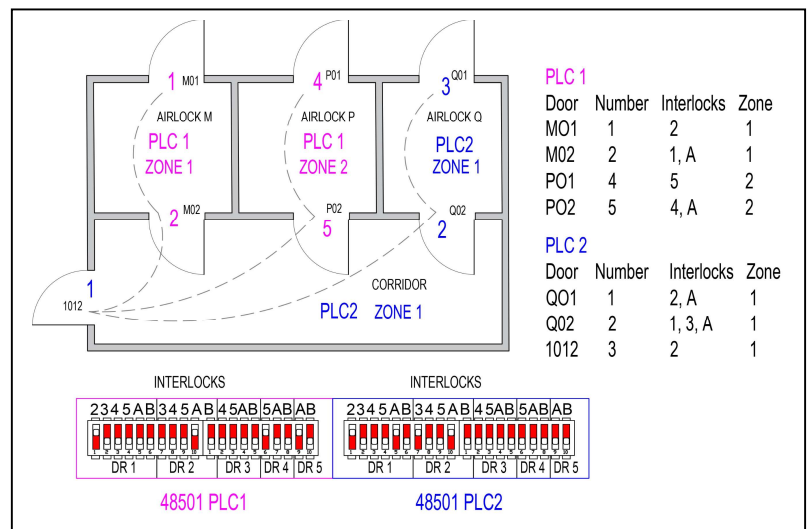

CONNECTING THREE 48501-EZ CONTROLLERS

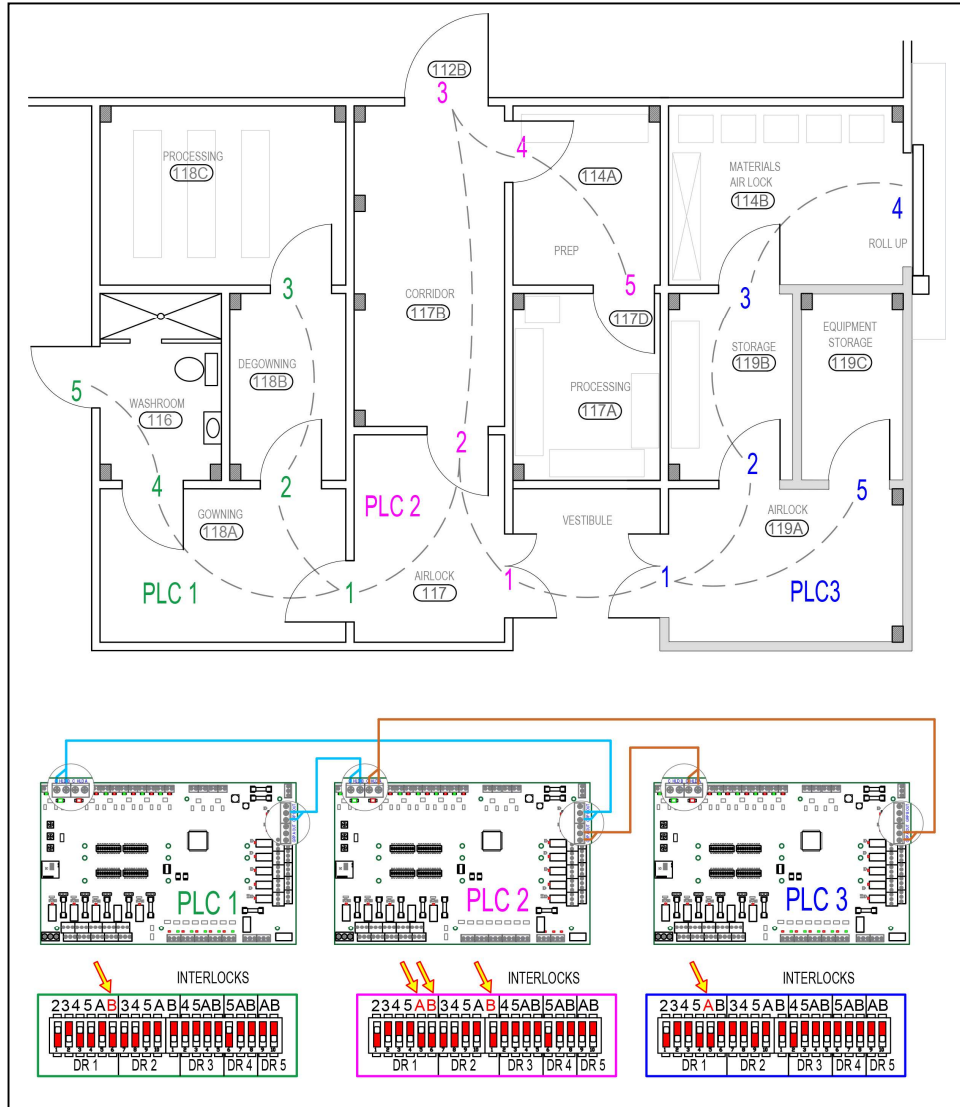

Above is an illustration of three controllers operating fifteen doors using the A & B HOLD function to communicate between controllers. An interlock table is helpful to visualize the relationships.

Note: PLC 2 shares door green 1 with PLC 1 and door blue 1 with PLC 3.

PLC 1 interlocks door 1 with B. When green door 1 has an active request for access (REX) or is open, the B output relay on PLC 1 changes state. The B output is wired to PLC 2 B input. It signals PLC 2 to deny access to any doors interlocked with B. In the example above PLC 2 doors 1 and 2 are interlocked with B. If PLC doors 1 or 2 are active or open, the PLC 2 B relay energizes signaling PLC 1 to deny access to green door 1.

PLC 2 shares interlocked doors with both PLC 1 and PLC 3. The A inputs and outputs are used to interlock door 1 on PLC 2 with door 1 on PLC 3.

The HOLD function works best for situations where only a few doors are shared between controllers. It is not suitable for more complicated interlock tables involving large groups of shared doors. Call Dortronics (800) 906-0137 to talk over alternative solutions.

INTERLOCK TABLE

Door Interlocks With

- P1-1 P1-2, P1-4, P2-1, P2-2
- P1-2 P1-1, P1-3, P1-4
- P1-3 P1-2
- P1-4 P1-1, P1-2, P1-5
- P1-5 P1-4
- P2-1 P1-1, P2-2, P3-1
- P2-2 P1-1, P2-1, P2-3 P2-4
- P2-3 P2-2, P2-4
- P2-4 P2-2, P2-3, P2-5
- P2-5 P2-4
- P3-1 P2-1, P3-2, P3-5
- P3-2 P3-1, P3-3, P3-5
- P3-3 P3-2, P3-4
- P3-4 P3-3
- P3-5 P3-1, P3-2

P1 = PLC 1 P2 = PLC 2 P3 = PLC 3

USING VIOLATION TRACKING

When contamination is an important consideration, or for high security facilities, it may be important to have a record of door violations.

There are five door status out relays on the right side of the board. See **R** on board diagram page 1.

The relays have double row terminals. The lower terminals follow door status in normal mode.

Note: *in ADO mode the relays signal an Automatic Door Opener and the violation reporting feature is disabled.*

In normal mode the top row of terminals can be used to signal that an individual door is in violation. It could be forced open, propped open, or open at the same time as an interlocked door.

The top row of terminals is enabled when a door violation alarm is true. When the door alarm is active any open door will show closed contacts on the upper terminals. **Connect to the normally closed contacts for this feature.**

CONSIDERATIONS:

- The violation reporting function only works when the DIP SWITCH is set for DPS out. When set to ADO mode the function is disabled.
- To report a propped open door, the propped door alarm must be enabled.
- To report a forced door (open without a valid REX) the forced door alarm must be enabled. See the section on initial configuration.
- Relay contacts are DPDT. For door status out, connect to the normally open contacts. For door in violation reporting, connect to the normally closed contacts on the secondary upper row of terminals.
- All DSI relay contacts are dry contact.
- Zones may be reported separately. **Install jumpers at J13 and J12 for single zone operation.**
- **Without jumpers J13 and J12 the default is 2 zone operation.**

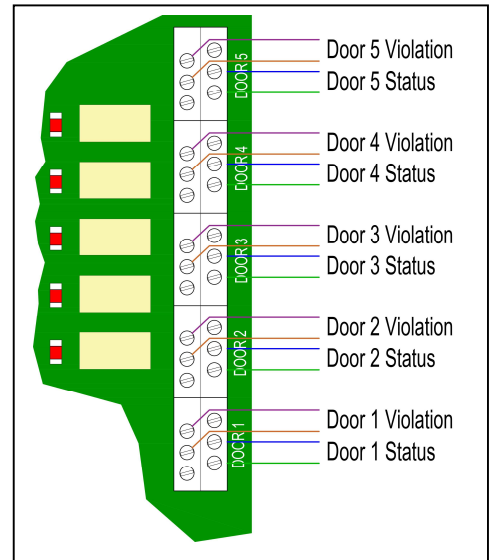

USING ONE-WAY LANES – PGM3

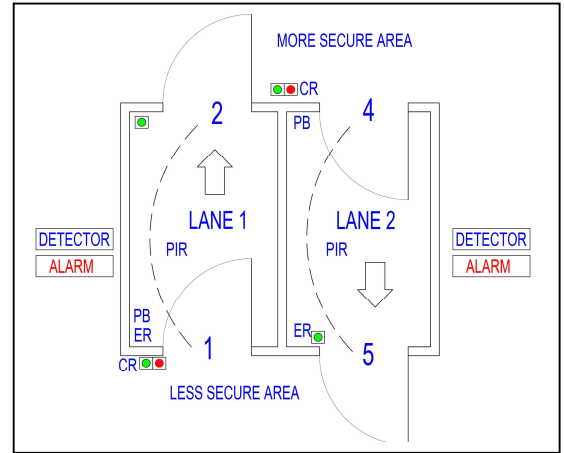
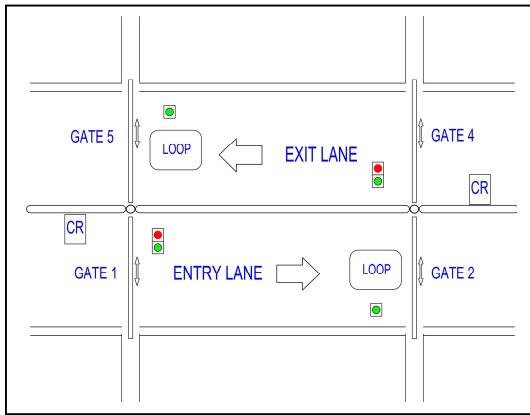

The LANE function is useful for any one-way interlock using automatic doors for pedestrian traffic or automatic gates for vehicular traffic.

When enabled, Lane mode creates two independent one-way interlocks.

Move DIP switch labeled PGM 3 to SET (up) to enable Lane mode. Doors 1 and 2 become an entry lane and doors 4 and 5 become a second independent lane. Door 3 is not used.

Lane Mode can not be used at the same time as ADO Mode.

The lock outputs become OPEN requests to a door operator.

If desired, locks can be operated by the primary set of contacts and the secondary set can be wired to the door operator.

Be sure power jumper is set to D for connection to door operator.

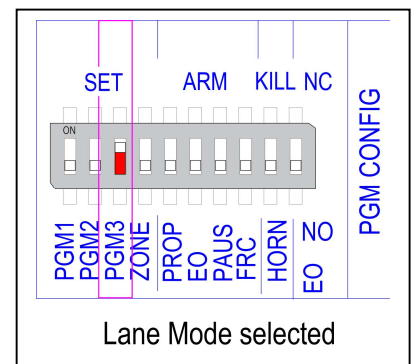

Theory of Operation.

Both lanes operate the same way. There is an exterior door or gate opening from the less secure area and an inner door or gate opening to the more secure area.

An individual presents a credential to a reader at the exterior door. If the inner door is secure, the outer door opens to admit the individual to the trap. Exterior traffic light turns green. Interior traffic light is red. When the outer door closes, the inner door opens automatically to allow the occupant to leave the trap. Exterior light turns red and the card reader is inhibited. The interior light turns green. The occupant leaves the trap. Inner Door closes. Exterior light turns green. Interior light turns red. Card reader at exterior is enabled. Only one door may be open at a time.

Using an Occupancy Sensor

The lane function may be used without an occupancy sensor. If used, connect occupancy sensor for lane 1 to door input for door 3. Connect occupancy sensor for lane 2 to REX input for door 3. See wiring diagram below.

Using a tailgate detector, metal detector or similar

HOLD A and B inputs are used to connect a detection system that generates an alarm for an abnormal condition. Hold A is for lane 1 and Hold B for lane 2.

If there is a scanner alarm while the exterior door is open, it is held open and the violation alarm relay energizes. The occupant(s) must leave the mantrap. When the exterior door closes, the individual may card in again.

If the HOLD input goes active after the inner door has opened, the alarm sounds, but it may be too late to prevent passage through the trap. It is important to ensure the detector alarms on an anomaly before door 1 has closed.

More than one scanner can be connected in parallel to the HOLD input. When the HOLD input is active (shorted) Door 2 remains unavailable.

WIRING DIAGRAM FOR ONE WAY LANE MODE

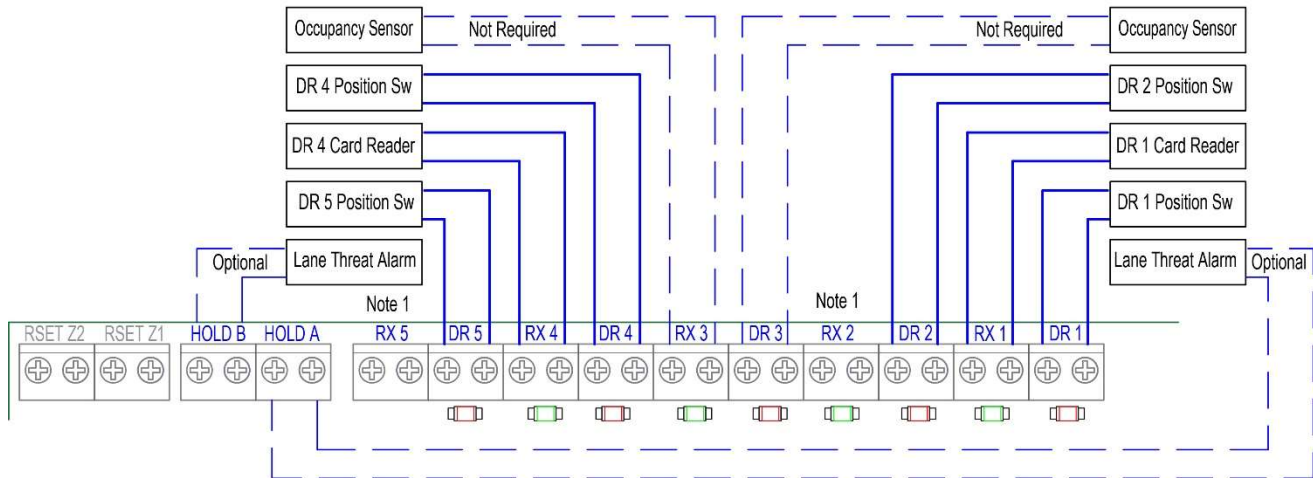

NOTE 1: The REX input for door 2 opens door 1 if the mantrap is occupied after door 2 closes (individual trapped). For this feature, an occupancy sensor is required. The REX input for door 5 opens door 4 if the mantrap is occupied after door 5 closes. Occupancy sensor is required.

If the trap is still occupied after a completed entry cycle, for instance the occupant fails to leave the trap after door 2 opens or an individual fails to clear the trap after a scanner alarm. The occupant must exit the trap via the exterior door.

When the trap is occupied and not in a normal entry cycle, the exterior traffic light at door 1 turns red. The door 1 card reader is disabled. The **door 2 REX** input is enabled **to open door 1** to allow the occupant to exit to the less secure area. Connect a pushbutton (PB) inside the trap at door 1 to the door 2 REX input.

LANE SHUNT

When the shunt input is shorted, Occupancy and Hold are disabled. Exterior and interior lights are green. Door sequence is the same. Shunt 1 is for lane 1 and Shunt 2 for lane 2. Use shunt for guided visitors.

LANE CONFIGURATION

1. Set DIP Switch PGM 3 to the armed position (up).
2. Interlock DIP switches are ignored in LANE mode. Doors 1 and 2 are interlocked as are doors 4 and 5.
3. If occupancy sensor is not used, action is a simple open/close cycle. Door 1 opens to allow an individual to enter the trap. When door 1 closes, door 2 opens to allow the occupant to exit the trap.
4. Be sure DIP switches for PGM 1 and 2 are off (down).
5. Note: *The zone setting is ignored in Lane mode.*

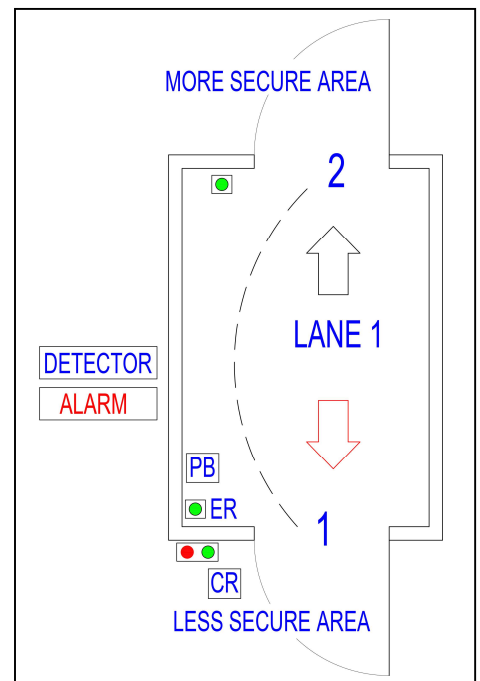

CONSIDERATIONS

- For exit lane operation, a motion detector or wave switch can be used instead of a card reader to enter the trap.
- A door that swings into the trap may be read as an occupant by a motion detector.
- For critical high security operation with special requirements, a custom 4900 controller may be needed.
- The emergency override opens and holds open inner and outer door to allow unrestricted egress.
- Use the EO input for cleaning services or equipment movement through the trap. Use a keyed switch or keypad to prevent unauthorized use. Both doors are held open as long as the EO input is shorted.
- The forced door alarm applies only to exterior doors.
- If no occupancy sensor is used **be sure door 3 input is open.**

ADDITIONAL SETTINGS

FORCED DOOR ALARM DISABLE

Default = Forced Door Alarm enabled.



For doors with access control entry (card readers and similar) and with mechanical exit (crash HOLDS, electric strikes with lever release and similar), turn off the forced door alarm.

Move the DIP switch to the ARM position to disable the forced door alarm. Move the switch down to enable, which is the default position.

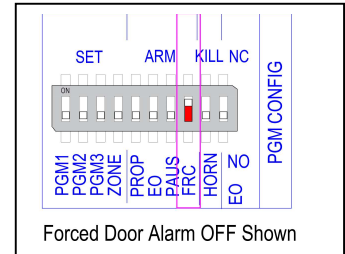

DOOR ALARM RESET OR SILENCE

Default = Automatic Alarm Reset. With the reset inputs shorted, the alarm ends when the alarm condition is corrected

Alternate setting = Manual Reset. Connect a switch, card reader, keyed switch or similar to reset an alarm with a momentary contact.

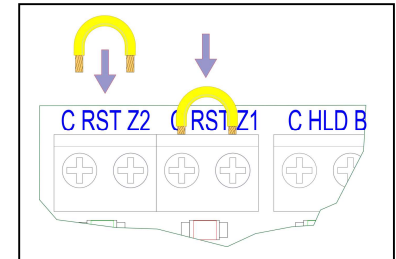

SILENCE ALARM WITH SEPARATE RESET

- To silence an alarm sounder without resetting an alarm
- Set HORN to the KILL position.
- This feature can only be used in single zone mode.
- When a door alarm is active, both door alarm relays 1 and 2 energize.
- Connect a sounder to the zone 2 alarm relay using wet contacts and connect zone 1 alarm relay to a light or desk console to indicate that the door alarm is active.
- Reset 1 will end the alarm condition and return the system to normal operating mode.
- Reset 2 will only reset door alarm 2 silencing the sounder, but it does not reset the alarm condition.

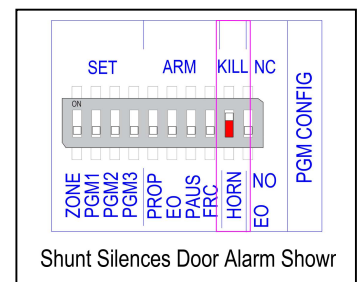

INTERLOCK BYPASS - SHUNT

Shunt bypasses the interlock.

This can be used to allow unrestricted access at certain times of the day, or to allow for maintenance or cleaning service to open more than one door at a time for the movement of materials, or equipment.

Connect a normally open maintained contact switch (typically a keyed switch, but a card reader, keypad or other secure input device could be used) to the SHUNT input. The interlock function is disabled for as long as the shunt switch contacts are closed. Any normally locked doors remain locked and must be opened by means of the normal access control sequence, however multiple doors normally interlocked may be open at the same time.

Door alarms for forced door, interlock violation and propped open are disabled when interlock is shunted. Traffic lights are green.

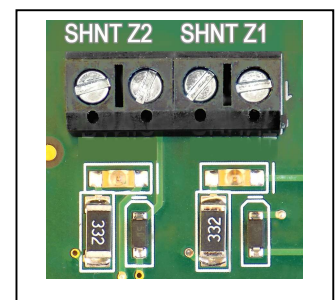

TROUBLE SHOOTING THE INSTALLATION

Visual indication of all inputs, outputs and system status is provided for verification of all conditions and settings. If the installation does not operate as desired, check the following in the sequence shown:

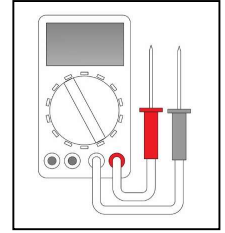

NOTHING WORKS

1. Check Mains for 110 VAC
2. Check VAC light is illuminated on 4204-NX power supply
3. Verify power supply is not in Fire Alarm shutdown – see 4204-NX manual
4. Verify 4204-NX DC LED is illuminated
5. Verify 12 – 24 VDC at supply output terminals

CHECK SYSTEM STATUS LIGHTS

1. **POWER LIGHT** – Must be illuminated. If not, check supply output, and fuse – see 1-5 above
2. **WATCHDOG LIGHT** – Blinks at a constant rate of 3 blinks per second. If not, cycle the power to the controller. If not resolved, call Dortronics Technical Assistance.
3. **TMR** – when lit indicates a timer is running. Disable timers to verify normal operation.
4. **EO** – Emergency Override is active. Check EO trigger setting: for N.O. panic input LED should be off. For N.C. panic input light should be on. Output relays will not change state when EO is active.
5. **ALARM** – If alarm is lit, find cause.
 - a. All doors should be closed showing red lights at each input. Remember: door switch must close, shorting input, when door is closed.
 - b. Short out the RESET Z1 and RESET Z2 inputs. If that resolves the problem, jumper out reset inputs unless HORN – KILL DIP switch is armed. See section on alarm reset or silence.
6. **IDLE** – Idle light indicates system is READY, doors are closed and no REX inputs active, no timers are running, and no alarms are active. If IDLE is not lit:
 - a. Verify inputs are correct.
 - b. Verify that each door that is to be interlocked by the controller is closed and that the input LED for each interlocked door is lighted. Unused door inputs can be jumped out if needed.
 - c. If it is not possible to keep the doors closed while troubleshooting because the facility is in use, temporarily jump the door inputs for all interlocked doors. Use a short piece of wire as a jumper. Jumper unused door inputs as well.

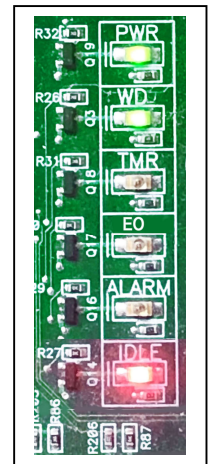

ANNUNCIATOR LED ERROR CODE PATTERNS

TIMER AND EO LEDS BLINK ALTERNATELY

Error code for **PGM1 and PGM3 both selected**. Unselect one of them.

IDLE LIGHT BLINKS

Error code for **no interlocks are set**. Interlock at least 2 doors.

IDLE NOT LIT WHEN SYSTEM NOT ACTIVE

CHECK INPUTS

- a. Check door input lights are lit. Remember, the door switch contacts must close when the door closes.
 - b. Check no timers are running
 - c. Check no alarms are active. Momentarily short out RESET 1 & 2 to verify.
 - d. Check HOLD A & B inputs not active. Temporarily disconnect to verify.
 - e. Check EO is not active. Toggle EO NO/NC trigger switch to verify.
2. Check no REX inputs are lit
 - a. Verify that no REX inputs are active and that no rex input lights are lit.
 - b. Make sure door is correctly configured. Verify that the door configuration DIP switch is set to “LOCKED” for the door being tested. If it is set to unlocked, the REX input is ignored.
 - c. To test a REX input, use a short piece of wire to jump the two REX input terminals. Verify that when a designated REX input is active, the corresponding lock relay changes state (shown by the relay LED for the lock relay being tested). Door 1 REX operates Door 1 lock and so on.
 - d. Check SHUNT input is not lit.

DOORS DO NOT LOCK

CHECK OUTPUT RELAYS

1. When a relay is energized a red LED illuminates.
 - a. When the system is **IDLE** and the idle light is on, verify that all normally unlocked fail secure doors show a lighted (energized) relay.
 - b. Are the relays on when they are supposed to be?
 - c. Verify that all normally locked fail secure relays are not energized (relay LED is off).
 - d. For Fail Safe settings, the relays should be ON when locked and off when unlocked at idle.
2. If the relays do not reflect the desired state check:
 - a. The door configuration is correct for the desired operation.
 - b. The door position inputs for all doors in the interlock are closed – the input LED is on.
 - c. check that no REX inputs are active – REX LEDs are all off.

Make sure the doors are correctly set for the desired operation. For a normally locked door, set switch corresponding to the door to the “on” or up position. For Fail Safe lock operation, set the switch corresponding to the door in the up or “ON” position.

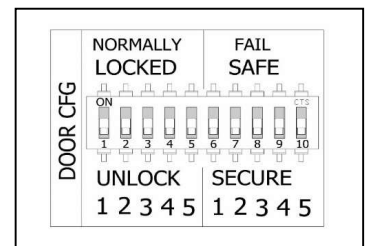

NO LOCK POWER

1. Check the lock relay fuse.
2. If the controller supplies power to the locks check that the jumper is on the **W** position. Use a multi-meter to verify that lock relay common is at the supply voltage.
3. Check that the lock is connected to the correct output. For Fail Secure operation the mag lock connects to N.C. contacts. Strikes connect to N.O. contacts.
4. Substitute a known good power jumper.

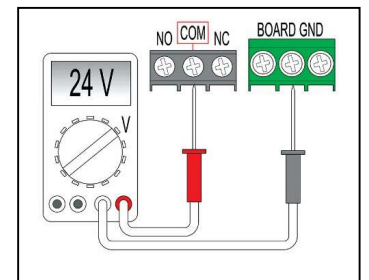

STAYS IN DOOR ALARM

1. Check that all interlocked doors are closed - door input LEDs are “ON”. If there is any doubt that a door position switch is operating correctly, use a piece of wire to jumper the input. DPS inputs have red LEDs. REX inputs are green LEDs.
2. Check that the Panic (emergency unlock timer) is not set and running. System Idle light should be lit.
3. Verify RESET inputs are shorted for auto-reset.

DOOR UNLOCKS WHEN IT SHOULD LOCK

1. Verify door is set for LOCKED operation.
2. Check Fail Safe/Secure switch is correct.
3. Check lock is connected to the correct relay contacts.

DOOR LOCKS WHEN IT SHOULD UNLOCK

1. Verify door is set for LOCKED operation.
2. Check Fail Safe/Secure switch is correct.
3. Check lock is connected to the correct relay contacts.

DOOR WON'T UNLOCK VIA REX WHEN INTERLOCKED DOORS ARE SECURE

1. Verify system is IDLE before activating the REX
2. Check A and B HOLD inputs are not active. Temporarily disable A or B interlock via DIP switch.

DOORS REMAIN UNLOCKED AT ALL TIMES

1. Check System Status EO light. If on,
2. Check that the Panic N.C. – N.O. switch is set correctly. In NO position, emergency override triggers on closed contacts at the EO inputs, one for each zone. In the NC position, EO triggers on open contacts at EO input.

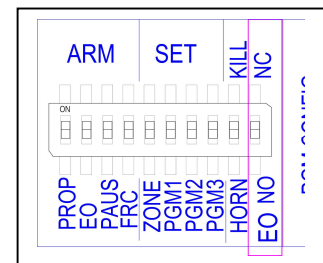
**TRAFFIC LIGHTS DO NOT ILLUMINATE**

1. Check the light array fuse with a multi-meter for continuity. Be sure the board is powered down.
2. Make sure the diode polarity is correct.

DOORS 4 AND 5 WILL NOT INTERLOCK WITH DOORS 1, 2, OR 3

1. Verify ZONE is off.
2. Alarm light will blink if Zone is set and doors are interlocked across zones.

DOORS DO NOTHING – NO INTERLOCKS

1. Verify at least one interlock is selected
2. IDLE light will blink if no interlocks are selected

DOORS WILL NOT UNLOCK

1. Check locked/unlock switch is set correctly
2. Check fail SAFE/SECURE switch is set correctly
3. Check locks are wired to correct relay contacts.
4. Check HOLDA and HOLDB inputs are not active.
5. Verify relay changes state when EO is activated.

NO RELAY CHANGES STATE

1. Trigger the EO input. Relays change state? If not, contact Dortronics tech helpline.

ONE-WAY LANE ISSUES

EXTERIOR CARD READER DOES NOTHING

1. Verify Occupancy input not active.
2. Verify inner door is closed and inner door input LED is lighted.
3. Check HOLD alarm not active. Input is not lighted. Remove connection to verify.

Verify PGM1 and PGM2 DIP switches are off.

INNER DOOR REX OPENS OUTER DOOR

1. Inner door operation is automatic. REX for inner doors 2 and 5 are used to open doors 1 and 4 respectively to release a trapped individual.

DOORS STAY OPEN

1. Check EO not active. Verify EO status light is not lit.
2. Check correct connections at door control relay. Use N.O. contacts to signal door operator.

OUTER DOOR STAYS OPEN

1. Check HOLD not active.

DOOR 1 & 2 LANE UNRESPONSIVE – DOOR 4 & 5 LANE OK

1. Check Door 3 input is not active. If occupancy sensor not used, make sure nothing is connected to Door 3 input.

POWER SUPPLY SPECIFICATIONS

The 4204NX power supply/charger converts a 120VAC 60Hz input into a single PTC protected Class 2 power-limited output. Output is selectable for 12VDC or 24VDC with a total of 4A max. It also offers a suite of features that includes fire alarm disconnect, overvoltage protection, and low power disconnect which prevents deep discharge of stand-by batteries.

<p>Input</p> <p>Voltage 120VAC, 60Hz, 3.5A max. Fusing 5A / 250V.</p> <p>Outputs</p> <p>Voltage 12VDC or 24VDC selectable. Current 4A continuous max. Protection Fused 2.5A / PTC 2A. Auxiliary Class 2 power-limited @ 1A (unswitched). Other Overvoltage protection. Filtered and regulated.</p> <p>Back-up Battery (<i>not included</i>) Capacity 7AH / 12VDC (1 or 2 within enclosure). Type Sealed lead acid or gel type. Fuse Rating 5A @ 32VDC. Failover Upon AC loss, instantaneous.</p>	<p>Fire Alarm Disconnect</p> <p>Supervised Latching or non-latching. EOL 10K Resistor.</p> <p>Supervision</p> <p>AC Failure Form "C" contacts. Battery Form "C" contacts. Low DC Power Shutdown Shuts down DC output terminals if battery voltage drops below 71-73% for 12V units and 70-75% for 24V units to prevent deep battery discharge.</p> <p>Indicators (LED)</p> <p>Input 120VAC is present. DC Output Powered. Battery Discharged or not connected.</p>
---	---

CONTROLLER SPECIFICATIONS

	Qty	Description	Remarks
Power In		12 or 24VDC regulated - plus, common and earth ground	3 - Screw Terminals
Inputs	18	5 DPS, 5 REX, 2 EO, 2 Shunt, 2 Alarm reset, A&B Hold	Screw Terminals
Outputs	24	5 Locks, 5 Door Status, 10 R/G Lights 2 Alarms, A&B Hold	Screw Terminals
Timers	3	Single Turn Rotary Adjusters to set Time Delay	
Temperature		Operating 0-60° C	
Mounting		DIN Rail Clip or Standoffs	
Dimensions		7" W x 10 7/8" L x 1 3/4" H – with DIN Clip installed. 1 1/4" H without	
Fuses	8	2 Amp @ 250 Volts – quick blow	

Current Draw - Condition	Current in mA	Volts
Controller only	< 100	12
with all relays on – all indicator lights lit	< 255	12
Controller only	< 80	24
with all relays on - all indicator lights lit	< 150	24

RECOMMENDED EQUIPMENT

DORTRONICS PART#	DESCRIPTION
Dortronics #1110xD	1200 lb electromagnetic 12/24 VDC maglocks with built-in door position switch.
Dortronics #7201xL2-H	High intensity Red / Green LEDs on single gang S/S wall plate.
Dortronics #7202xL2-HxCS	High intensity Red / Green LEDs with Piezo sounder on double gang S/S wall plate. (Optional for use with security breach alarm output.)
Dortronics #5216 MP23PP/RXE2	Panic mushroom switch latching push, pull.

SALES - WARRANTIES

Product Warranties:

All electromagnetic locks have a **LIFETIME GUARANTEE** against defects in material and workmanship. Defective units will be replaced or repaired based upon incoming evaluation and inspection.

All other Dortronics components of the Electric Locking System shall be similarly warranted for a period of one year. Expressed warranties are conditionally based on the requirement that the items covered within the guarantee are used and maintained in accordance with the manufacturer's recommendations. The full warranty policy is accessible on our website. <https://dortronics.com/sales-policies-and-procedures/>

A Return Authorization Number must be obtained and accompany all returns within 14 days of issue. Unused items returned for credit must be complete and packed in original unit box and are subject to a 15% restocking fee. Any shipping or order discrepancies must be reported within 5 days of receipt.

www.dortronics.com

