



4300 SERIES 2 DOOR INTERLOCK CONTROLLER

The 4300 series 2-Door interlock controller is an inexpensive alternative for 2 door mantraps. It features 2 powered relay outputs for direct connection to locks and traffic lights if used. It may be easily configured during installation for locked, unlocked or locked-unlocked operation by means of jumpers. It also features an optional Remote connection to provide for override of one or both door locks by remote console, panic switch or a similar actuator.

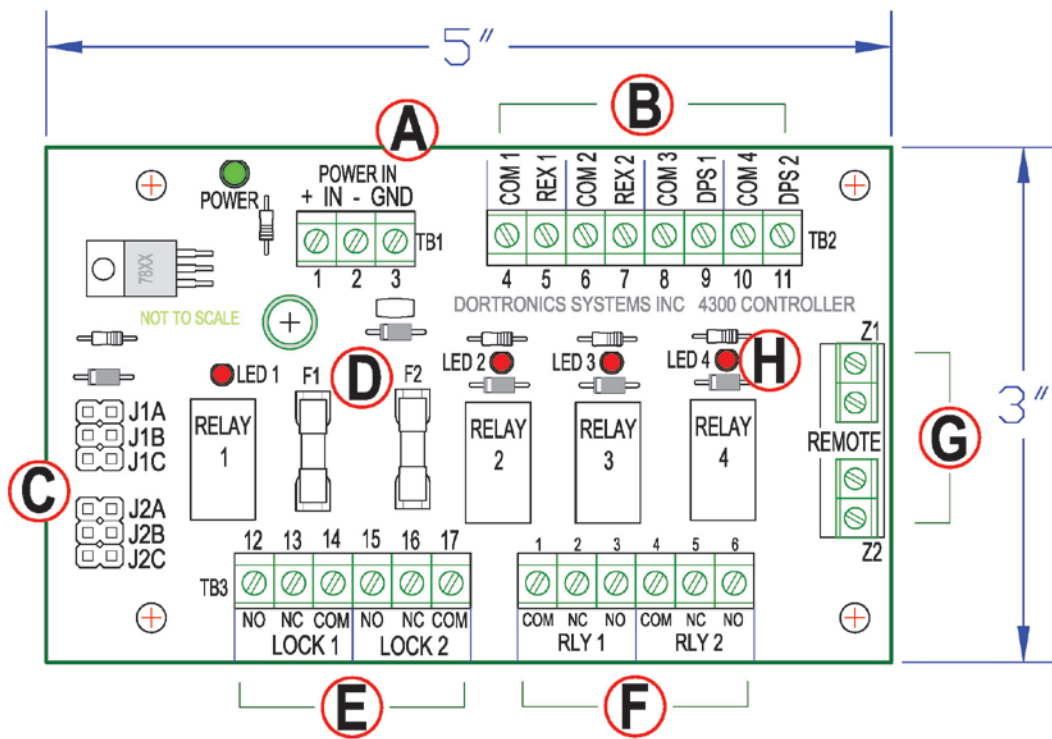

FIG. 1 CONTROLLER DIAGRAM

- | | | | |
|---|-----------------------------|---|------------------------------|
| A | Power Input – 12 or 24 VDC | E | Lock Power Output |
| B | Control Inputs | F | Optional Non-powered Outputs |
| C | Configuration Jumper Matrix | G | Remote Lock Override |
| D | Output Fuses | H | Relay State Indicator LEDs |

HOOKUP

The standard 4300 series controller comes mounted in a 12" x 15" x 4" metal, locking NEMA enclosure and includes a 4 Amp power supply with trickle charge output for battery back-up. The supply may be quickly set for either 12 or 24 VDC output (12 VDC as shipped). The supply features a Fire Alarm Interface. A signal from an external fire alarm (normally closed dry contact) will cause the power supply FAR interface relay to de-energize cutting low voltage power to the system and releasing the door locks. A 2 Amp supply is available as an option. Refer to the Power Supply User's Manual (included) for more details.

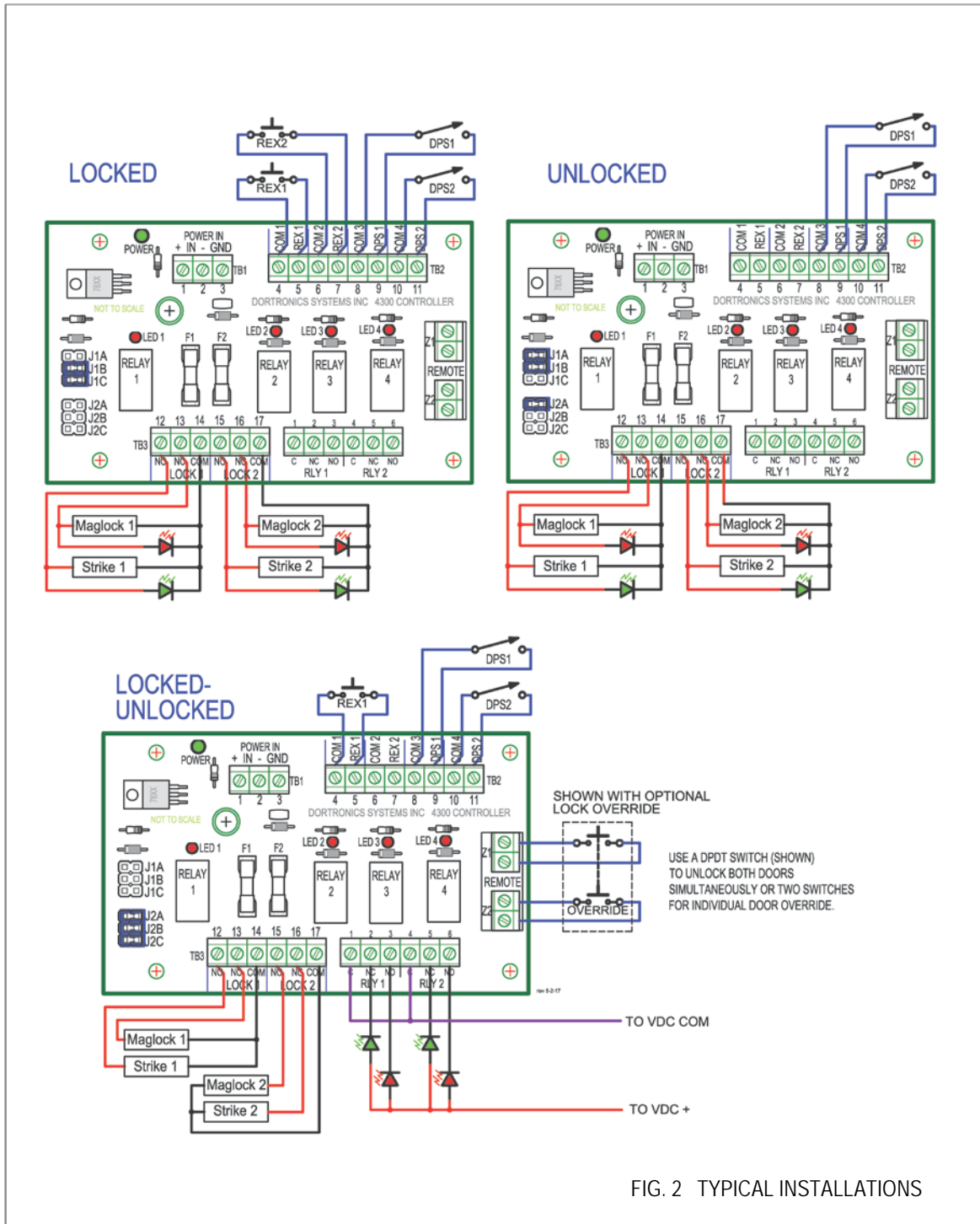

FIG. 2 TYPICAL INSTALLATIONS

DOOR POSITION SWITCHES

Door switch contacts must be closed when the door is secure. Twisted pair wiring – AWG gauge 22 or larger is recommended.

REQUEST FOR ACCESS DEVICES

Door unlock time is determined by an external device, typically a card reader, motion sensor, pushbutton or remote console. Only normally open dry contacts should be used. Do not apply voltage to a 4300 input.

DOOR LOCKS

Maglocks and strikes are connected to the powered outputs directly. Both powered outputs are fused. LED indicators to indicate lock status may be wired in parallel (as shown)

NOTE:

Connect Maglocks to the normally closed relay contacts and fail-secure electric strikes to the normally open contacts so that the door is unlocked when the associated relay is energized. Fail-safe strikes (unlocked when power is removed) should be connected to the normally closed contacts.

Use a wire of sufficient diameter and rating to minimize voltage drop, especially over long wire runs. AWG 18 gauge is recommended for power circuits. Do not connect loads greater than 1.5 Amps to a powered output. Make sure diodes are used on maglocks to prevent back EMF (standard on most DORTRONICS locks).

TRAFFIC AND LOCK STATUS LIGHTS

LED and incandescent indicator lights (typically red to show a locked or inaccessible condition and green to show an unlocked or freely accessible condition) may be connected as shown in Figure 2. Note that the red LED can be connected in parallel with the maglock and the green in parallel with a strike, or they may be connected to the dry contact non-fused outputs (RLY 1 = Door 1).

AWG 22 gauge or larger is recommended for signaling and low-power indicator circuits.

PANIC EGRESS OR REMOTE UNLOCK

The 4300 controller offers an optional Lock Override function. The Remote lock override terminals may be connected to a set of dry contacts. On closure, the associated door lock relay will energize, unlocking the door and bypassing the interlock function for as long as the switch contacts are closed.

Both doors can be unlocked simultaneously by using a double pole double throw switch. Multiple DPDT switches can be used in parallel if needed, but be sure to wire correctly. The Lock Override function is separate and in addition to the Fire Alarm Relay on the power supply that kills power to the locks and controller in the event of a fire alarm condition. The override is useful to unlock doors in the event of a door position switch failure, a stuck door, an environmental emergency or any other reason that requires immediate egress regardless of interlock status.

Building codes vary by location. The installer is responsible for understanding and working in compliance with all local codes and regulations as defined by the governing authority.

TESTING

Indicator LEDs for each relay indicate if the relay is energized. There are 2 output relays and 2 logic relays. The action of the logic relays will depend on the desired type of operation, and is selectable by changing the jumper positions. Make sure the pattern of jumpers is correct for the operation required. Doors should be unlocked when relays are energized. Door position switch contacts should be closed when the door is closed.

Caution: Do not short the powered outputs! If a fuse blows, replace it with the proper value - **1.6 Amp** quick blow.

RECOMMENDED EQUIPMENT	DORTRONICS PART #
1200 lb electromagnetic 12/24 VDC maglocks with built-in door position switch.	1110xDxB
Electric Strike 12 or 24 VDC adjustable with integral door switch	3300xD & 3301xD
High intensity Red / Green LEDs on single gang S/S wall plate.	7201xL2-H
High intensity Red / Green LEDs with piezo sounder on double gang S/S wall plate. (Optional for use with security breach alarm output.)	7202xL2-HxCS

OPTIONS	USEFUL ADDITIONS FOR ENHANCED SECURITY	DORTRONICS PART #
Auxiliary DPDT Dual Pack	Auxiliary DPDT relay pair may be driven directly by powered outputs to provide additional switching capacity, may be connected to non-powered outputs and supply to mirror lock status to multiple remote devices, or may be used to convert wet contacts at input to dry contacts.	4802001
Keyed Maintained Contact Mushroom Switches	The Dortonics 5200 series of mushroom switches are available keyed and non-keyed. They may be connected to the Remote inputs to provide an interlock override for immediate egress regardless of door status.	5200 Series
4 Amp Power Supply	For double door, or paired maglock installations, the 4 Amp power supply is recommended	4202-4
Battery Backup	7 Amp hour battery backup for locks and controller fits in the enclosure and can provide up to 6 hours of continuous security during power outages. Batteries may be ganged for longer backup times.. Battery is continually trickle charged when power is provided to the system.	XBATT
AT and ET Timer Modules	Allow for timing functions fully adjustable between 1-60 sec.	AT or ET Timer

SPECIFICATIONS

	Qty	Description	Remarks
Power Supply		12 or 24VDC selectable, with switched outputs, non-switched outputs and battery trickle charge outputs.	3 - Screw Terminals
Inputs	4	Digital 9 - 32 VDC rating use dry contact only	Screw Terminals
Outputs	2	SPDT Powered outputs for direct connection to locks and lights.	Screw Terminals
	2	SPDT non-powered relay outputs - rated 1.6 Amps @ 30 VDC	Screw Terminals Option
Temperature		Operating 0-60° C	
Dimensions		3" W x 5" L x .75" H	
Current		40 mA @ 24 Volts. Controller only	



Dortonics locks come with Transient Voltage Suppressors. Connecting an inductive load to a Dortonics controller without "kickback" (back EMF) protection will damage the relay contacts and void the WARRANTY.

TVS diodes are available from Dortonics. \$1.00 ea.
Part # 1200036





SALES - WARRANTIES

Contact (Sales):

Mike Palermo – Sales/Customer Service

Stuart Arthur – Sales/Applications Specialist

Bryan Sanderford - National Sales Manager

Contact (Technical):

Joe Hanna – Engineer/Applications Specialist

Contact (Credit):

Kelly Hillerud – Accounting; New Customer Accounts



Product Warranties:

All electromagnetic locks have a **LIFETIME GUARANTEE** against defects in material and workmanship. Defective units will be replaced or repaired based upon incoming evaluation and inspection.

All other Dortronics components of the Electric Locking System shall be similarly warranted for a period of one year. Expressed warranties are conditionally based on the requirement that the items covered within the guarantee are used and maintained in accordance with the manufacturer's recommendations.

A Return Authorization Number must be obtained and accompany all returns within 14 days of issue. Unused items returned for credit must be complete and packed in original unit box and are subject to a 15% restocking fee. Any shipping or order discrepancies must be reported within 5 days of receipt.

www.dortronics.com