

1107xD SLIM LINE MAGNETIC LOCKS

Slim Line Magnetic Locks



Features:

NFPA 101 / BOCA Compatible

600 Pounds of Holding Force

Shallow 1-1/4" Mounting Profile

Efficient-Low Current Draw

Certified to UL294 for Access Control

Ultra Slim Profile:

Designed to fit narrow style header applications, the 1-1/4" lock body depth greatly reduces the need for angle mounting brackets and filler plates, saving installation time and expense.

Reliable & Versatile:

This state-of-the-art electromagnetic locking device provides positive, instantaneous door control. Models are available for single outswing, inswing, and sliding doors or gates. Filler plates, angle brackets, and other mounting adapters are available to accommodate a wide range of door and frame types and conditions.

NFPA Life Safety Compatible:

Electromagnetic locking devices function independently of mechanical locks and are ideal for use with fire and hazard detection systems to provide unobstructed egress upon loss of power due to an alarm condition.

Concealed Door Status Switch:

A concealed Door Position Switch is included to report door status to monitoring equipment for the detection of open Propped or Forced door conditions.

Safe Operation:

All 1107xD electro-magnetic locking devices are inherently fail-safe, releasing instantly upon command or loss of power. Both locking and unlocking are accomplished with ease and efficiency. The well confined magnetic field of these locks allow them to be used in computer rooms and other electronically sensitive areas. The built-in Transient Surge suppression protects the electromagnet from voltage spikes.

Field Convert to Inswing:

The 1107xD Maglocks were designed to accept the 1095-07 Inswing Conversion Kit. Change from outswing to inswing door applications on site utilizing the kit which includes a Z-Bracket and angle mounting bracket complete with hardware and drilling template.

Field Convert to Inswing:

The rugged all-metal design and durable construction ensures unlimited lock and unlock cycles without electrical fatigue or mechanical breakdown. Our locks are manufactured to the most stringent quality control standards. This allows Dortronics to offer a *Lifetime Limited Warranty* on all 1107 Series electromagnetic locks.



1107xD MAGNETIC LOCKS WITH BUILT IN DOOR STATUS SWITCH

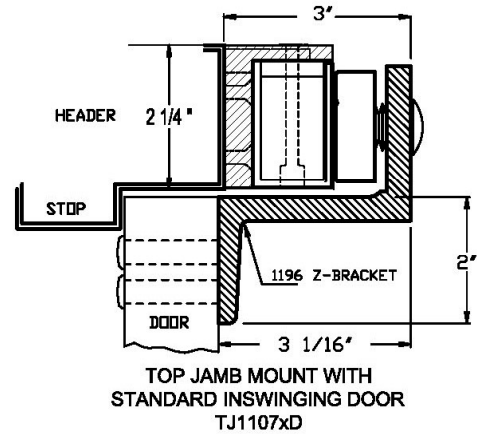
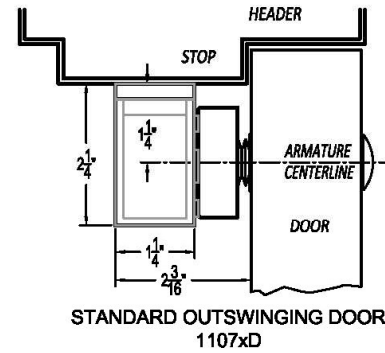
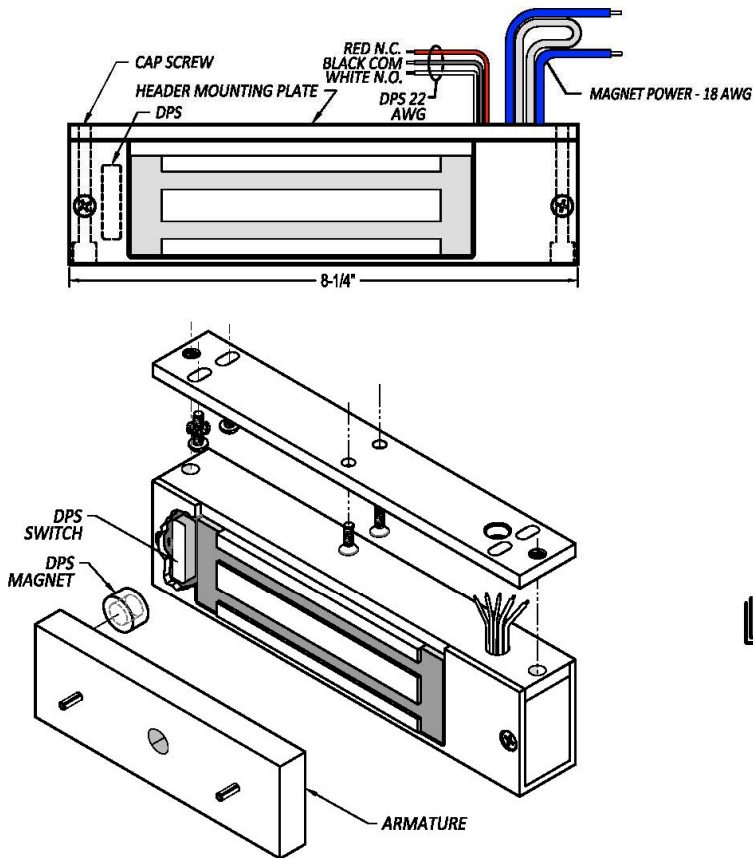

Specifications:

Models

1107xD – Single Door standard
Outswing (600 Lbs.)

TJ1107xD – Single Inswing Door With Z-
Bracket (600 Lbs.)

1195-07 Inswing/Gate Conversion Kit

Physical Size

1107xD Housing –
8-1/4" Long x 2-1/4" High x 1-1/4" Deep

TJ1107xD Housing & Angle bracket –
8-1/4" Long x 2-1/4" High x 1-3/4" Deep

Electrical:

Operating Voltage
(field selectable)
1107xD – 245ma @ 24VDC
480ma @ 12VDC

Concealed Door Position Switch SPDT
Rated @ 100 Milliamps @ 30 Volts DC

Finish:

1107 series locks are encased in a
brushed Clear Anodized Aluminum
Housing Electro-magnet face and
armature are Nickel plated for high
resistance to rust and corrosion.

Installation:

Typically, these locks are mounted on an
out swinging door using the Header
mounting plate accompanying the unit.
This mounting plate has elongated slots
for ease of alignment and threaded holes
for secure attachment of the lock to the
plate. An access hole is also provided in
the mounting plate to accommodate the
power and control wiring. The armature
plate mounts to the door with thru bolting
hardware provided.

Installation:

The TJ1107xD units are supplied with an
angle bracket prepared for attaching to
the face of the door frame. Z-bracket and
mounting hardware are also furnished
for the mounting of the armature plate to
the door or gate post.

**Field convert the 1107 to a TJ1107
with the 1195-07 conversion kit**



DORTRONICS SYSTEMS, INC.

1668 Sag Harbor Tpke., Sag Harbor, NY 11963 (800) 906-0137 (631) 725-8148 Fax www.dortronics.com