

Economical PLC Mantrap Control

PLC Door Interlock Controller

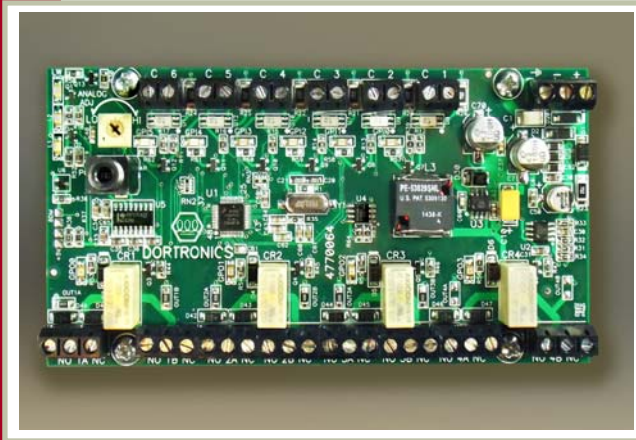

Typical Configurations:

#47211-U – Standard 2-Door / 1-Room
Normally Unlocked

#47211-L – 2-Door / 1-Room
Normally Locked

#47321-LU/S – 3-Door / 2-Room
1-Normally Locked & 2-Normally
Unlocked with 1-Shared Door

#47431-U/2S – 4-Door / 3-Room
Normally Unlocked with
2-Shared Doors

Secure Interlock Door Control

The 4700 series Programmable Logic Controller is an economic way to control up to 4 interlocked doors. The controller logic sequences simultaneous requests for access and monitors unsecured doors to maintain the highest level of security at all times.

Environmental or Security Control

Suitable for air locks or security mantraps, with up to four normally unlocked doors or three normally locked doors. The controller may also be customized to control automatic door openers and provide timing and logic sequences for biological wash-down controls.

Typical configurations also provide outputs for traffic lights, forced doors and an emergency panic release input.

Access Control Compatible

Any access control system can be used with the 4700 series controllers. The request for access input recognizes any normally open dry contact.

12/24 VDC Power Supply

The 4700 series PLC controller is paired with a heavy duty 4-amp power supply that includes a Fire Alarm connection for emergency egress and provides power to operate the maglocks and electric strikes and traffic lights.

An alarm output is also provided.

DORTRONICS SYSTEMS, INC

1668 Sag Harbor Tpke. – Sag Harbor, NY 11963
(800) 906-0137 - (631) 725-0505 - (631) 725-8148 FAX

System Layout Detail:

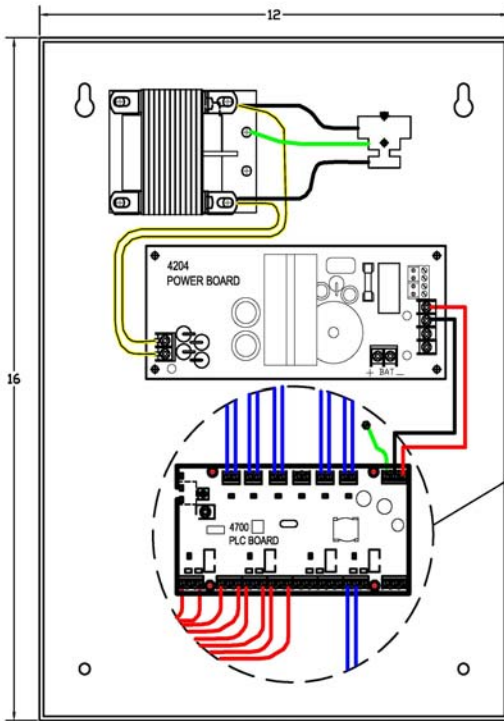

STANDARD ENCLOSURE MOUNTING

(FOR ILLUSTRATION ONLY)

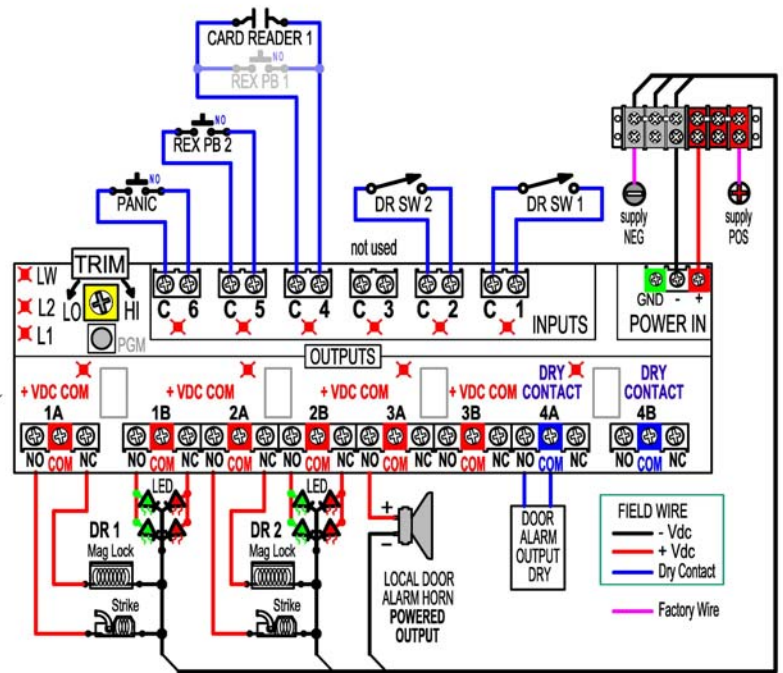

TYPICAL CONNECTIONS FOR 2 DOOR LOCKED INSTALLATION

Physical Data –

Enclosure- 12" x 16" x 4" deep NEMA enclosure will accommodate PLC controller & one I/O module with power supply. Additional modules may require larger enclosures.
 PLC Module - 5-1/2" x 2-7/8" overall

Electrical –

AC Input - Fused 110 VAC
 DC Output - 4 amp field selectable 12/24 VDC

Inputs –

Six Digital Inputs for Door Status (Dry contact closed when is door secure) and Request for Access (Dry contact normally open)
 1 analog trim pot input available.

Outputs –

Four Relay Outputs - DPDT Contacts rated 2 Amps @ 30 VDC for each door (Magnetic lock or strike & LED traffic indicators for each door. Relays 1, 2, and 3 have wet contacts (common is at supply voltage). Relay 4 contacts are dry (unpowered). One set of contacts for each relay is protected by Transient Voltage Suppressor Diodes. Contacts 1A, 1B, 1C, and 1D have TVS protection. An inductive load (mag lock, electric strike, solenoid etc.) should only be connected to outputs with a TVS.

Operation –

Only one door may be unlocked or open at any time. Unlocking or opening one door automatically secures all other doors within the designated area. A request for access at any normally locked door will inhibit the REX inputs for all other locked doors and secure all unlocked doors in the area.

Lock relay contacts will switch low voltage power to maglocks and/or strikes. The lock relay contacts also allow low voltage red and green LEDs to be utilized for indication of lock status. For user feedback, typically a green light indicates that access is permitted, while a red light signals that another door is open and access is denied at this door.

A single turn trim pot is available for setting timing delays and other variable inputs after installation. The function and adjustment range must be specified by the customer prior to ordering. Typical uses include: airlock equalization delay, Unlock time, Door Propped alarm delay, Failure to clear mantrap alarm time, Panic release unlock time. Call for additional information and pricing..